

**MITSUDA**  
Spray Nozzle

*High Performance  
and Overqualified  
Spray Nozzles for  
Surface Technology*



ISO 13027  
HIYEN VE SANİTASYON  
YÖNETİM SİSTEMİ

CERTIFIED  
ISO  
45001:2018  
COMPANY

CERTIFIED  
ISO14001

QUALITY  
MANAGEMENT  
SYSTEM  
ISO 9001  
CERTIFIED

TSE

CE

Surface Technology

[www.mitsuda.com.tr](http://www.mitsuda.com.tr)  
[www.spraynozzles.net](http://www.spraynozzles.net)  
[www.spreynozul.com](http://www.spreynozul.com)

**35.**  
*Years*

## Advanced Surface Technology as a Result of Nozzle Technology Improvements



Through our continuously developing engineering research, Mitsuda is offering high technology nozzle and spraying options that provides increasing product and surface impact quality. For all sectors working through surface treatments such as coloring, drying, rinsing, descaling.... the best results can be achieved through using the best fit nozzles designed for the required application.

Mitsuda provides perfect solutions to users through its wide range of products and 35 years' experience in surface technology applications. Our experienced team guide you to get highest working performance through adapting continuously developing nozzle and spraying technology.



Mitsuda has established successful partnerships that are still ongoing through many fairs world wide. The new technological era of virtual fair platforms also enable Mitsuda to present its engineering studies in the nozzle technology improvements.



# SURFACE TECHNOLOGY

## Pre-Treatment and Painting Systems



## Automotive Industry



## Food Industry



## Pharmaceutical Industry Electronic



### Content

### Page

Mitsuda Nozzles for Pre-Treatment and Painting Systems	3	Series M3.686	34
EASY - SCREWED LOCKED	14-15	Series MK12.688/MK13.689	35
MEMORY SPRAY	16-18	Series M4.490/491	36-37
Easy-Clip Nozzle Systems	19-20	Series M46.460/461	38-39
Series M2.632/633	21-23	Series MS.546/548/550	40
Series M8.650/651	24-25	Quick Couplings	41
Series M9.652	26-27	Glass Washer Nozzle	42-43
Series M10.676	28-29	Accessories	44-45
Series M11.646	30	Quick Jet	46-47
Series M12.612	31	Spiral Nozzles	48-58
Series MH.602/608/652	32	Eductor Nozzles	59-63
Series MFH.6FH	33	Air Nozzles	64-67

## Water Jet Cleaning Nozzles

Flat Fan Nozzles and tongue- type with eyelet clamps are the primary nozzle types in water jet cleaning processes. The components are subjected to wide range of fluids such as aqueous alkalies, deionized water.

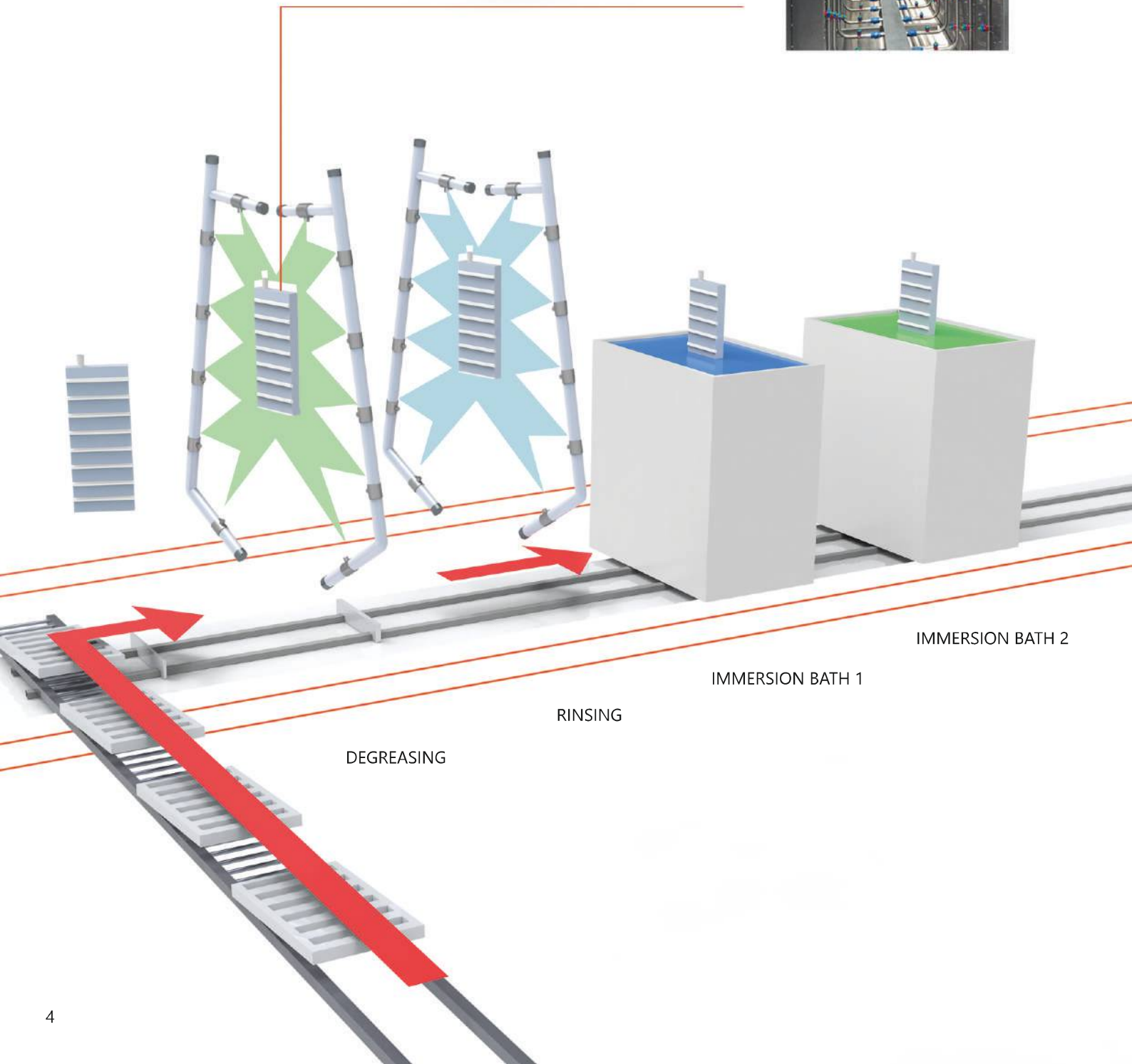

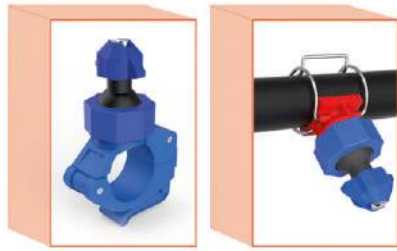

### Nozzles used for the Rinsing Zone

The components are entered into a rinsing zone at the end of the painting line where paint particles are thoroughly washed off. This is achieved step by step until deionized water is used.

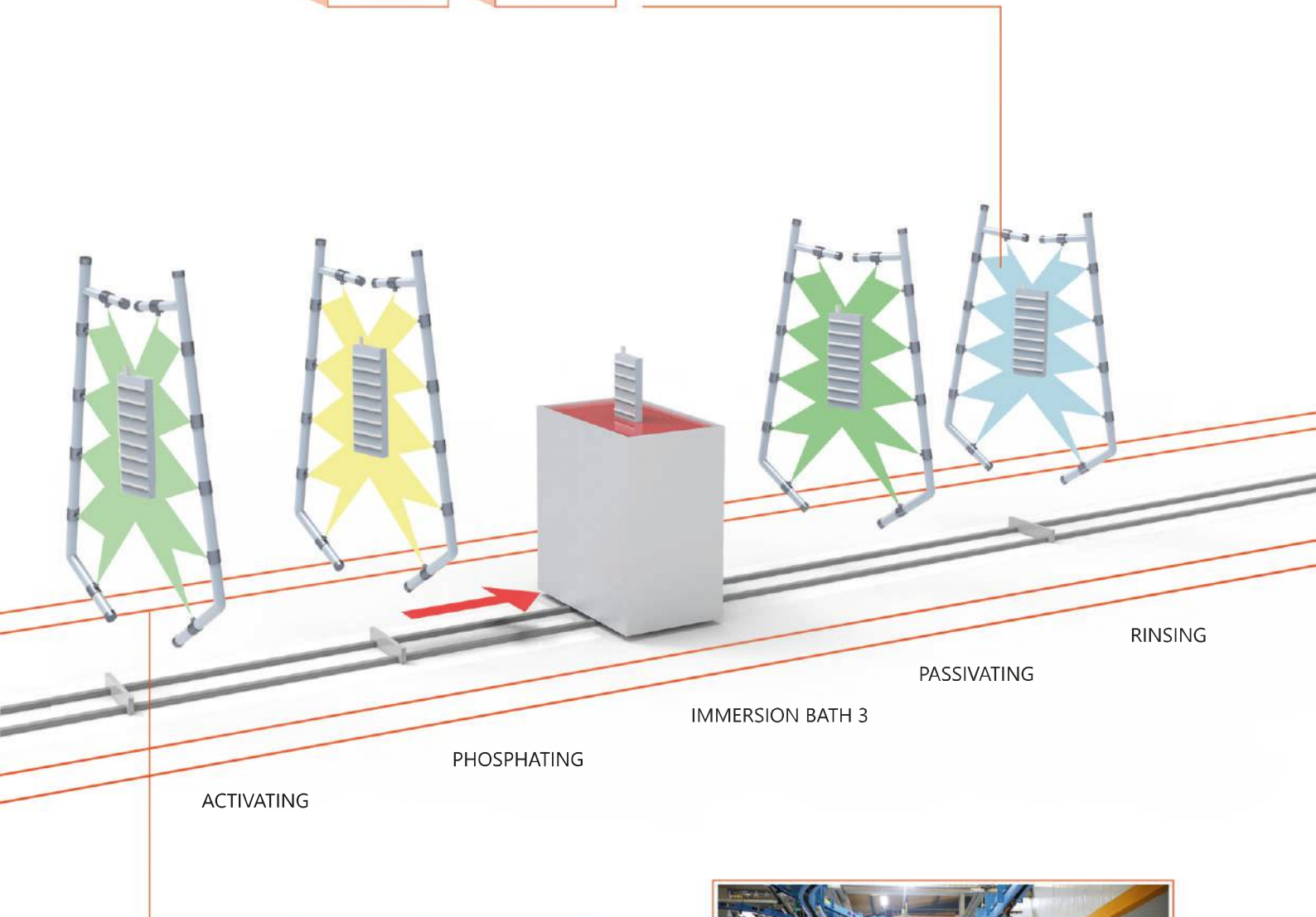

### Nozzles and installation options for Pre-treatment

Mitsuda offers wide range of nozzles and installation options for this application. (Please check MEMORY SPRAY, Easy-Clip, spacers and end caps for pipe installation).



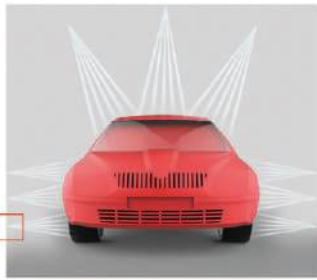

### Nozzles for the Pre-wash

Pre-wash is applied to soften the soil. Flat fan nozzles or tongue-type nozzles are the mostly used nozzles through their wide spray angles with a low flow rate.

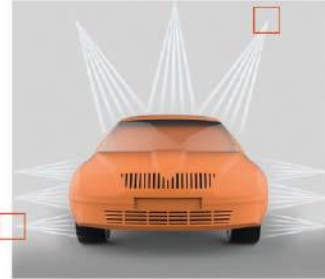

### Nozzles for the main wash

High impact flat fan nozzles or tongue-type nozzles are used for the main wash. The spray angle should be 30 to 45 degrees. Through their sharp jet, tongue-type nozzles are suitable for low pressure. High pressure flat fan nozzles are different from low pressure nozzles through their hardened mouthpiece which enables them to have a longer service life.

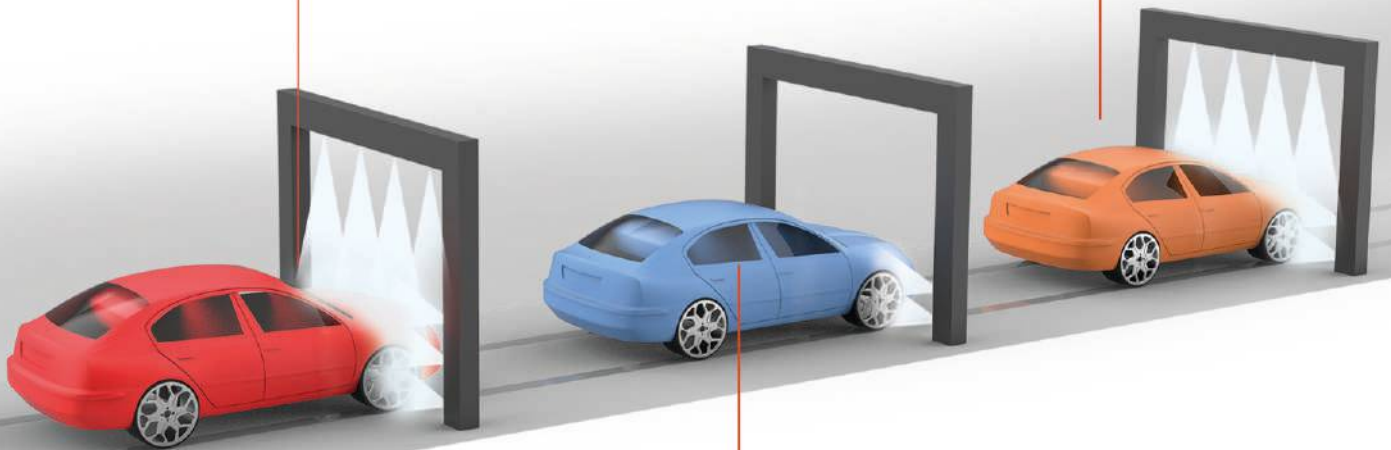

### Nozzles for sill and wheel washing

The area where soil is mostly found can be cleaned through a high spray impact. Mitsuda offers high-pressure nozzles designed with a narrow spray angle to best achieve this application.

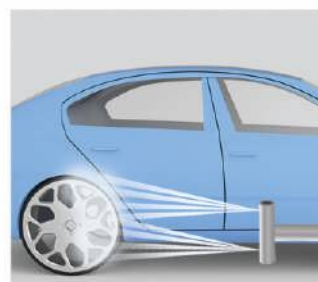

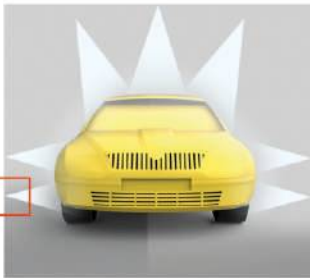

**Nozzles for Rinsing**

Rinsing is the previous stage before drying. This application requires small droplets which can be obtained through Flat fan nozzles. **Flat fan nozzles** use an extremely low flow rate and can be connected easily through aid of a bayonet cap and a ball joint.

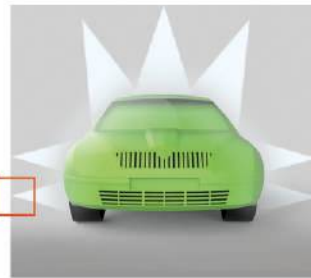

**Nozzles for applying wax**

To apply wax evenly, a specified nozzle adjustment is needed. Mitsuda's **conjunc on with a retaining nut and eyelet clamp** is the best solution for this application through disturbing the water perfect evenly.



**Alignment of low-pressure flat fan nozzles**  
Mitsuda **flat fan nozzles** provides a linear impact through providing an even droplet. To achieve this, the nozzles should also be aligned nearly 5-15 degree to the pipe's longitudinal axis.

### Nozzles for cooling, lubrication, chip removal



To get maximum effect for cooling and lubrication, spray nozzles should be correctly positioned. Nozzles could be aligned through using a ball joint. Tank cleaning nozzles operates for chip removal through cleaning the interior machine in CNC machining centers.

### Nozzles for Surface Pre-Treatment



Flat fan nozzles efficiently work in many pre-treatment processes of automobile industry. The MEMORY SPRAY and Easy-Clip nozzles are the commonly used nozzle systems in that area.

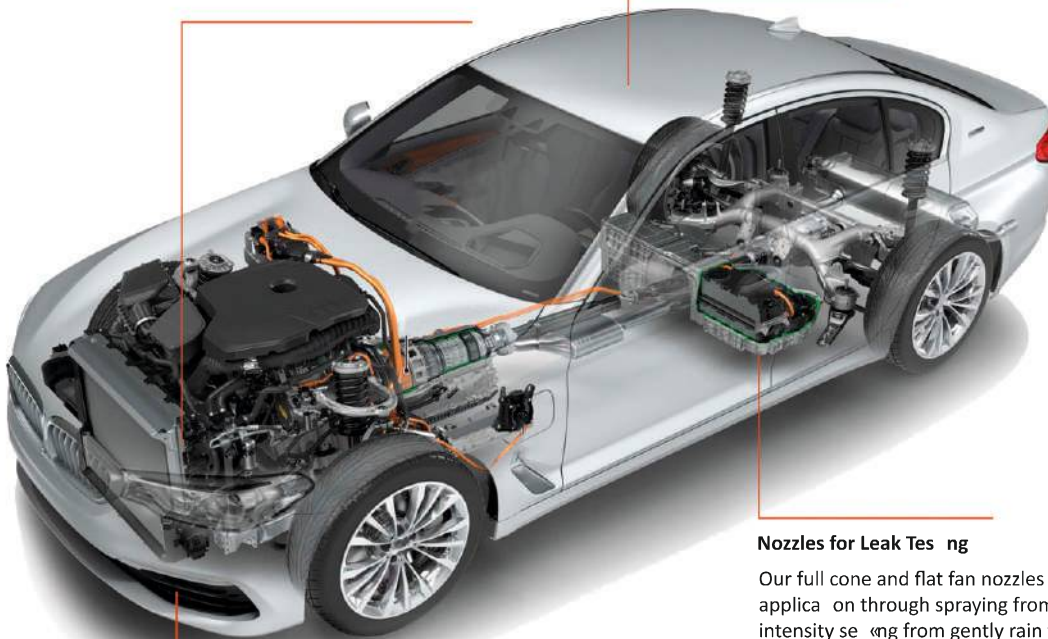

### Nozzles for Leak Testing

Our full cone and flat fan nozzles are commonly used in this application through spraying from all sides in different rain intensity setting from gently rain to heavy rain. Thus, cars are successfully checked whether they are well sealed against rain and moisture.



### Nozzles used in washing installations

Mitsuda presents different ranges of flat fan nozzles for this application. High pressure nozzles and tongue-type nozzles are some of them. The best cleaning outcome and low water consumption can be achieved through selecting the correct nozzle type. Mitsuda supports to install perfect nozzle systems through its wide range of products and 35 years experience in surface technology application.



### Nozzles for sill and wheel washing

The area where soil is mostly found can be cleaned through a high spray impact. Mitsuda offers high-pressure nozzles with a narrow spray angle to best achieve this application.

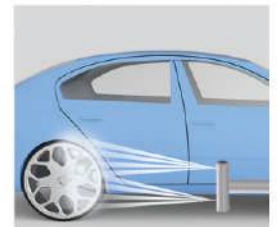



## The criteria for Nozzle Selection:

### 1- Impact

- | Impact surface and jet shape
- | Spraying distance
- | Pressure
- | Flow Rate
- | Jet depth

### 2- Spray angle and spraying behaviour

### 3- Liquid distribution

### 4- Droplet sizes

### 5- Factors affecting the temperature behaviour of nozzles materials

### 6- Material and wear

To determine the appropriate nozzles for you, the following criteria should be taken into consideration.

### 1- Impact

When a liquid jet applied on a surface, the force of impact has the key role in surface technology. The impact is calculated as the ratio of force to the surface.

The impact can be changed according to following parameters.

#### Impact surface and spray angle

The impact surface means the area that the droplet strikes. The smaller surface area leads to get higher impact values. Examples for the nozzles with high impact are flat fan nozzles and solid stream nozzles.

#### Pressure

Increased connected pressure leads to an increased spray impact. If the pressure is doubled while keeping the flow rate same, the impact is doubled.

#### Flow Rate

If the flow rate is increased through using a larger nozzle, the impact is increased (in case of keeping the order parameters such as spray angle, pressure medium same).

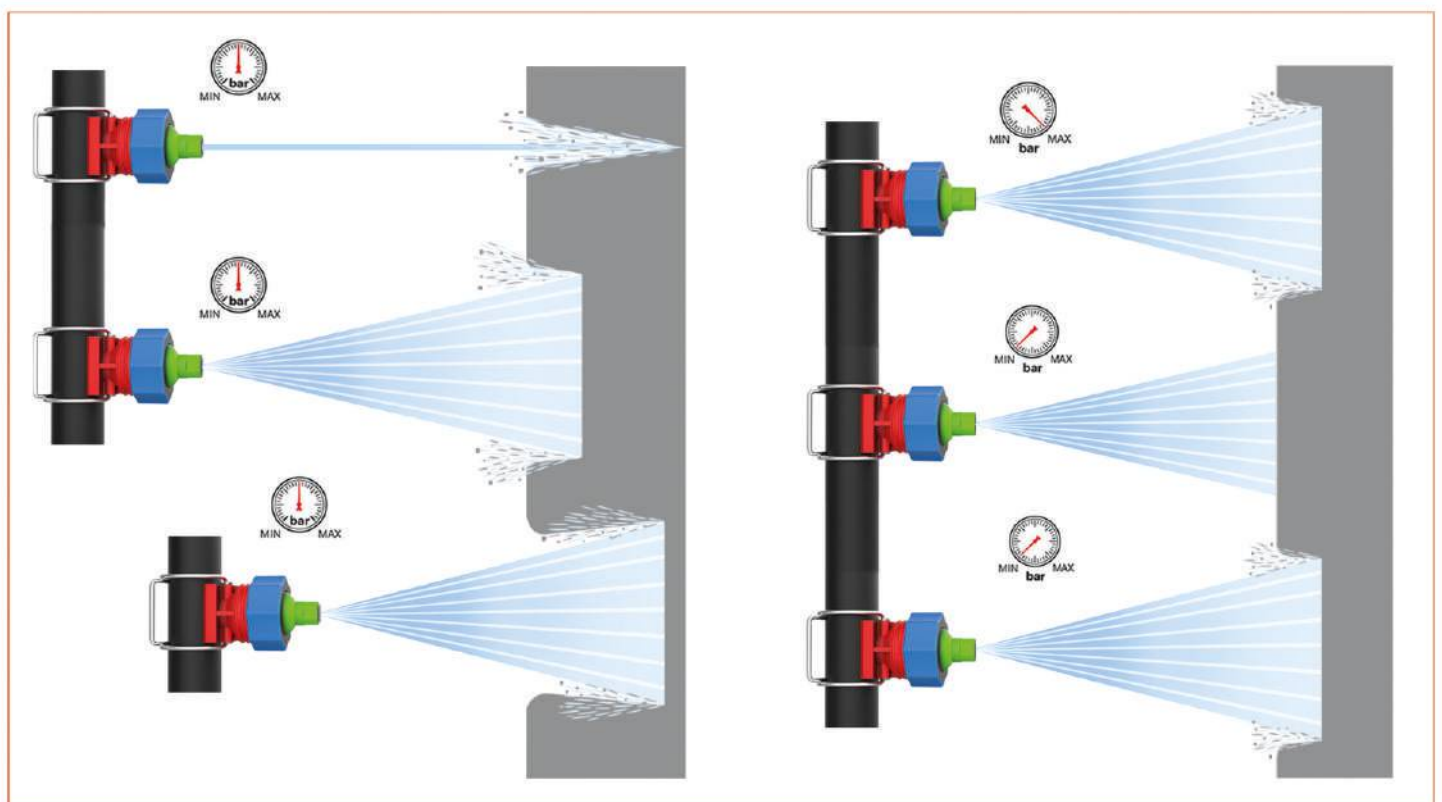

## Spray Depth

When using flat fan nozzles, the impact changes according to spray quality. For instance, through Mitsuda high pressure flat fan nozzles or a high flow quality, a narrower spray depth can be ensured. If other variables kept same (flow rate, pressure, medium, spray angle), a narrower spray depth leads to a higher impact.



- Through using a flat fan nozzle, doubling the distance leads to a quadrupling of the sprayed surface area.
- For atomization nozzles, if the distance is increased, the sprayed surface area also enlarges. This results in decreased impact on the surface.
- Regarding flat fan nozzles, if spraying distance is doubled, the sprayed surface area quadruples. As a result, the impact decreases four-fold.

## 2-Spray angle and spraying systems

There are different types of single-fluid nozzles with spray angles from 0 degree (solid jet nozzles) to 360 degree (tank cleaning nozzles). According to its type, single-fluid nozzles may spray liquid as a flat fan, full cone or hollow cone.

The solid jet nozzle provides a closed jet impact which hits a focalized point. The jet impact breaks up after some distance available. Twin-fluid nozzles, have a narrow spray angle of nearly 20 degree because of the high speed where the compressible medium available. If the distance from the nozzles enlarges, the spraying becomes less sharply. Twin-fluid nozzles produce flat fan or full cone spraying in general, but some different spray patterns might also be provided.

Distance	Area	Impact
h	A	I
1.5 x h	2.25 x A	1 / 2.25
2 x h	4 x A	1 / 4
3 x h	9 x A	1 / 9
4 x h	16 x A	1 / 16

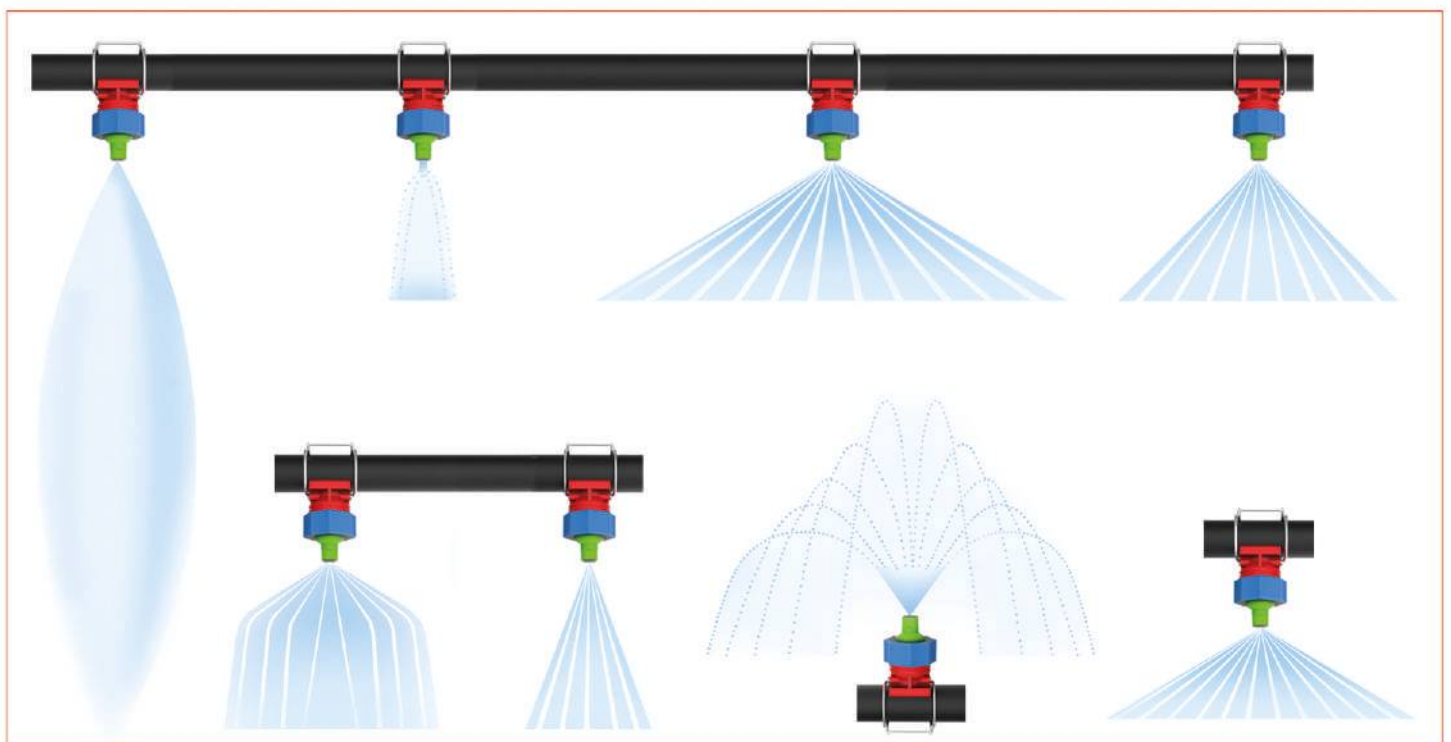

### 3- Distribution of Liquid

Regarding coating processes, homogenous distribution of the liquid is required. To ensure an even distribution of the liquid, nozzles must be aligned next to each other as one nozzle by itself provides a parabolic distribution. An overlapping nozzle adjustment achieves an almost even liquid distribution.

### 4- Droplet sizes

Twin-fluid nozzles may provide thin to very thin droplets based on flow rate ratio of the used compressible medium to the atomized liquid. If ratio increases, the atomization becomes thinner. For single-fluid nozzles, the droplet field changes according to nozzle design, flow rate and pressure. If pressure increases, the atomization becomes thinner up to a certain level.

Hollow cone nozzles, if pressure and flow rate kept same, produce thin to very thin droplets.

While Full cone nozzles produce coarser droplet spectrum, flat fan nozzles produce the coarsest spectrum. The nozzles with lower flow rate produce thinner droplet spectrum according to nozzles with higher flow rate.

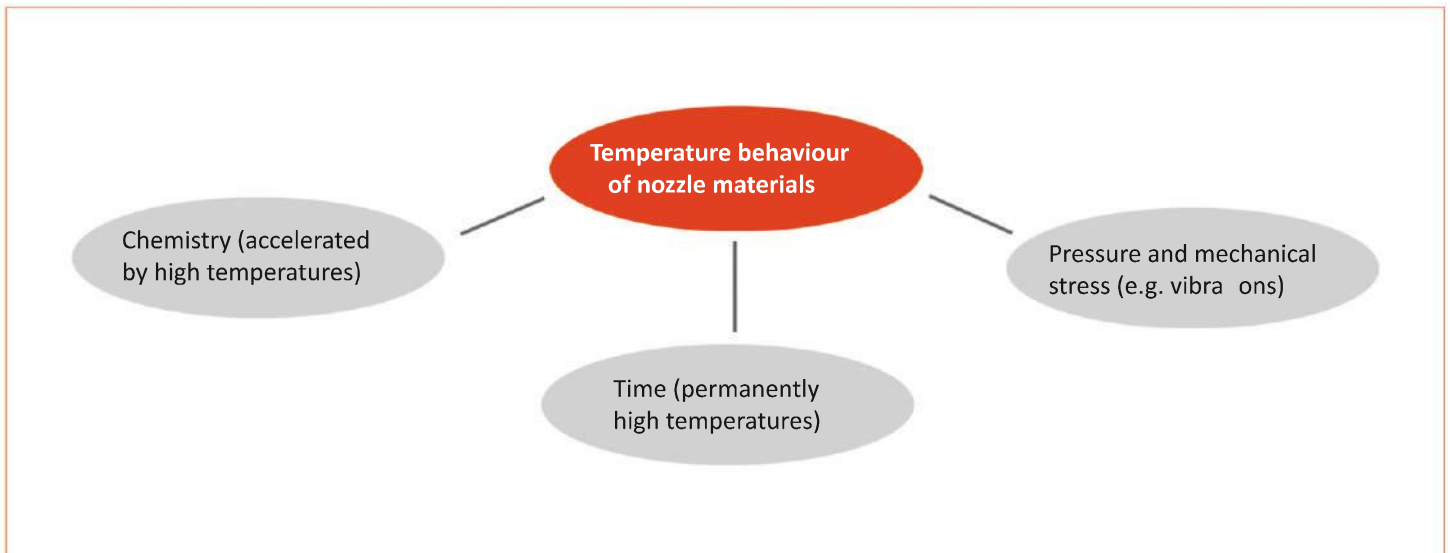

### 5- The use of nozzle materials according to different temperatures

Applications that require temperatures up to 140 degree are more common. Cleaning and sterilization applications are within this spectrum. Material data sheets shows temperature information that suitable for the used nozzle material.

The basic agents that effect the suitability of a nozzle material at higher temperatures are pressure, chemistry, time, and the associated mechanical stress. Chemical applications might require higher temperatures.

For all materials, high temperatures lead to decrease in strength values. So, for applications that require high pressure, the mechanical stress type must be focused on.

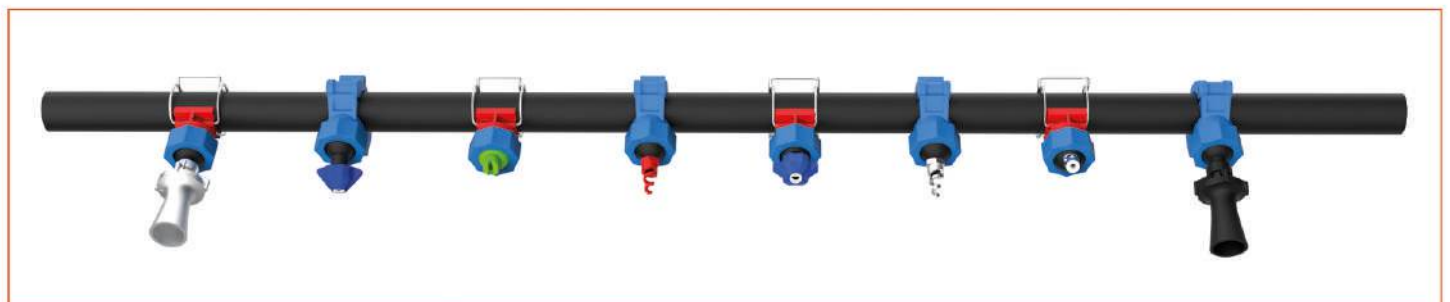

## 6- Nozzle Wear

The factors that affect the nozzle wear are the used nozzle material and using conditions.

Material abrasion caused the wearing of a nozzle's liquid outflow opening.

The below factors cause more wearing of the nozzles:

- | Using the nozzle above the optimal range of pressure.
- | Hard particles and solids in the liquid.
- | Using hard chemical substances.

In case of using nozzle in an improper environment such as radiation, high temperature, the nozzle body can also wear.

The Factors affecting the nozzle wear can be seen on below diagram.

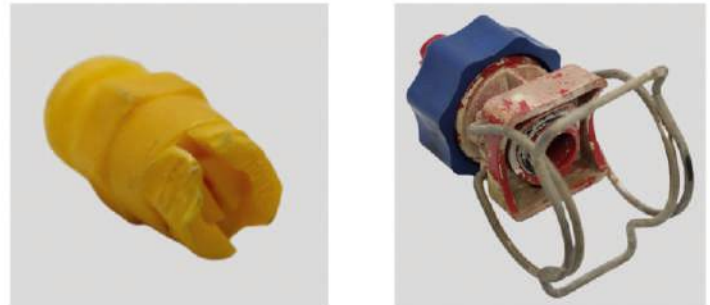

## Indication of nozzle wearing

A high increase in flow rate indicates the wearing of nozzles. The reason of increasing flow rate is the more liquid discharge because of material abrasion. This causes more freshwater consumption.

## Material wearing

In general, material wear is caused by the atomization of liquid with hard particles and solids. If those particles are harder than nozzle material, the ratio of wearing significantly increases. The table presents different materials and their average Vickers hardness.

Nozzle Material	Vickers hardness (HV)
Aluminum	80
Brass	80-150
Titanium (grade 1 to 4)	125-210
Hestelloy	200-250
Stainless steel	220-270
Stainless steel (hardened)	360-390
Carbide	1000-2300
Ceramic	1500-2700
Sapphire/ruby	2300

- Corrosive wear
- Abrasive wear
- Temperature
- Corrosive and abrasive wear

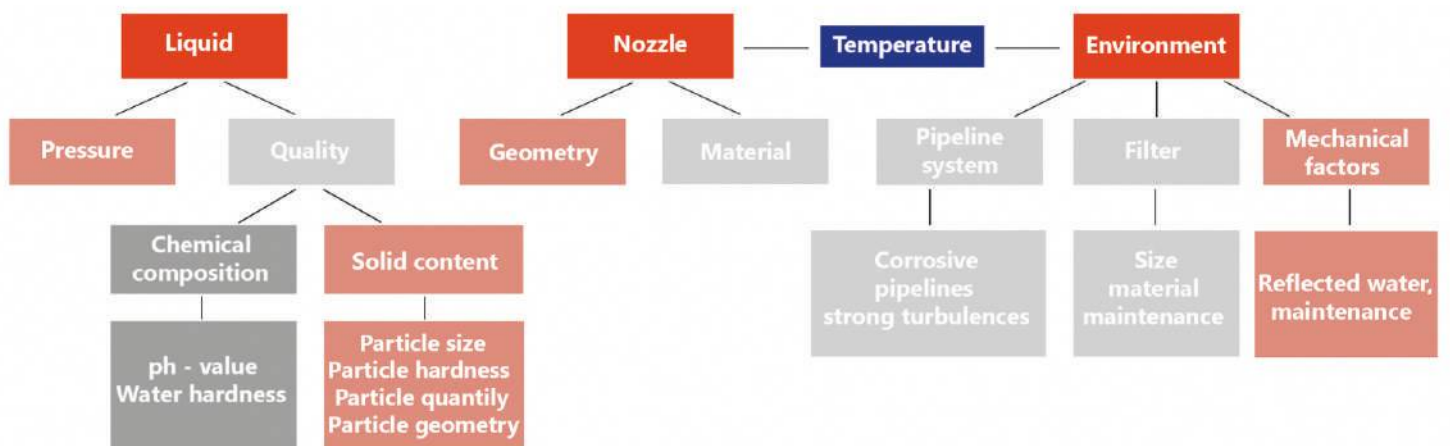



M.HAWK.01.16.01.53



M.HAWK.01.14.01.53



M.HAWK.02.16.01.53



M.HAWK.02.14.01.53



M.HAWK.02.11.01.53



M1.676.XXX.53.30.01



M.092.080.53.AX.01



M.067.630.53.40.00



M6.422



M46.460



M4.490



M2.632



M3.686

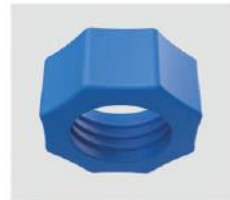

M.092.80.53.00.02

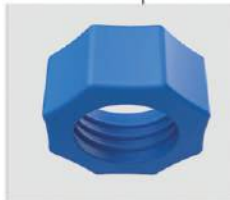

M.092.80.53.00.02

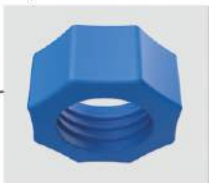

M.092.080.53.00.02

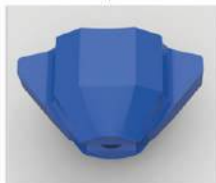

M7.676.XXX.E8.40

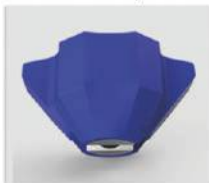

M7.676.XXX.8X.40



M7.676.XXX.E8.40

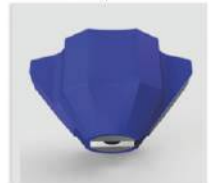

M7.676.XXX.8X.40





Code	PS	D	COLOR
	inch	mm	
M.Hawk.01.16.01.53	1-1/4	16	BLUE
M.Hawk.01.14.01.53	1-1/4	14	TURQUOISE
M.Hawk.02.16.01.53	1	16	RED
M.Hawk.02.14.01.53	1	14	ORANGE
M.Hawk.02.11.01.53	1	11	YELLOW

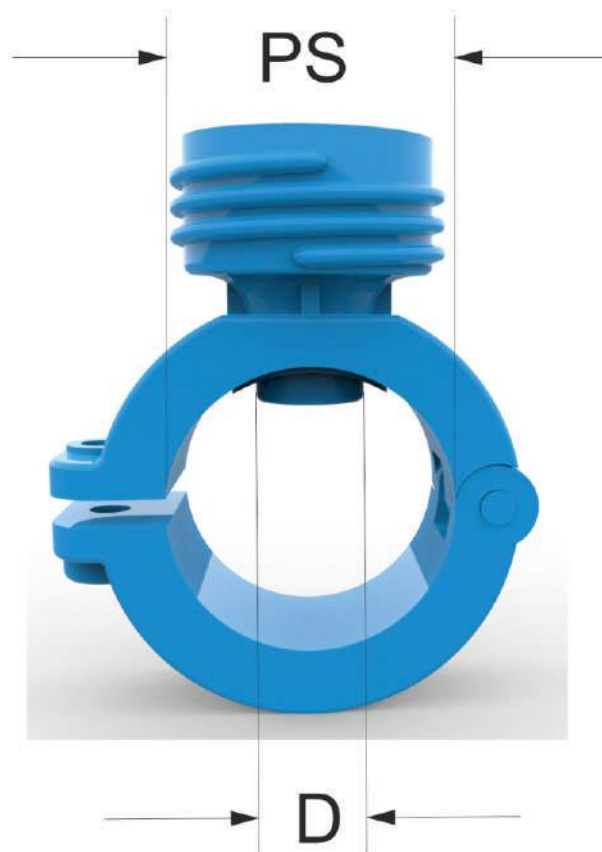

**Rotating nozzle clamps**

To apply those clamps on your pipes, a drill hole needed through which nozzle clamp inserted and linked via a screwdriver. The clamp body is made of PP mixed with %30 fiberglass. Bolts and screws are made of stainless steel AISI 316. Rotating nozzle clamps are long wearing and can be easily installed. You may also get optimum performance also at high temperature.

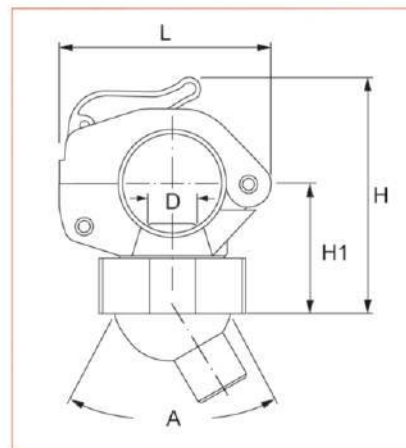
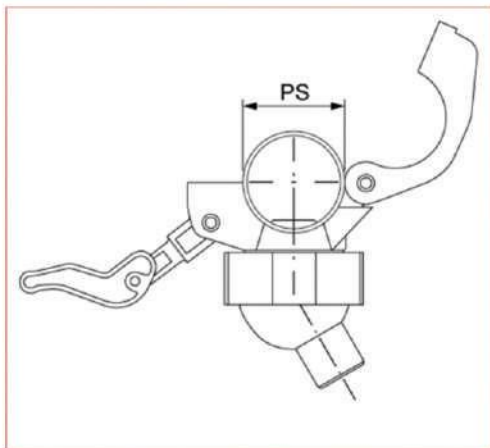

Code	PS	PD	D	H	H1	L	A	W
	inch	mm	mm	mm	mm	mm	deg	g
M.067.631.xx.40.00	1-1/4"	42/43	20,0	93	41	84	40°	87
M.067.631.xx.50.00	1-1/2"	48/49	20,0	96	44	95	40°	97



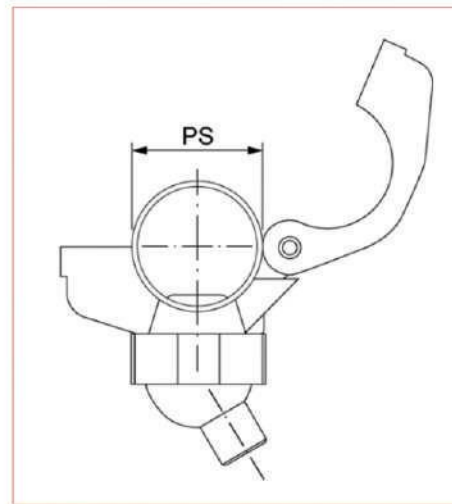
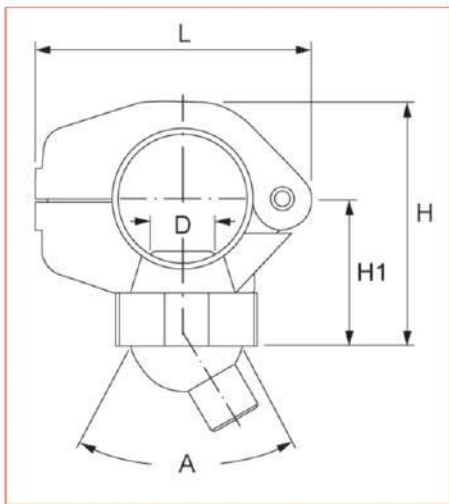

Code	PS	PD	D	H	H1	L	A	W
	inch	mm	mm	mm	mm	mm	deg	g
M.090.033.xx.40.10	1-1/4"	41/13	20,0	83	54	84	40°	85
M.090.033.xx.43.10		41/13	17,0	83	54	84	40°	85
M.090.043.xx.40.10	1-1/2"	46/49	20,0	90	57	90	40°	88
M.090.043.xx.43.10		46/49	17,0	90	57	90	40°	88





# Nozzle System for Surface Technology

## MEMORY SPRAY nozzle system

### MEMORY SPRAY nozzle system

To maintain installed spraying direction, the "memory effect" is the best tool through which nozzle alignment can be handled without any specific tools. Specially, pressure resistant pipe connector.

#### Treatments:

Phosphating in surface treatment, cleaning, degreasing.

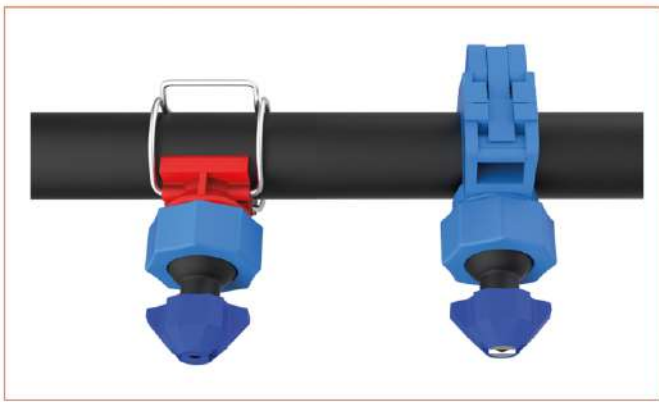

Type	Angle	Ordering no.	Material				Flow rate [l/min] bei p [bar]					Weight [g]				
			8F Housing: PP Insert: 303 SS	8R Housing: PP Insert: 316S SS	E8 Housing: PP Insert: ceramic	53 polypropylene (PP)	1.0	1.5	2.0	2.5	3.0	PP/303 SS	PP/316L SS	PP/ceramic	PP	
1 Flat fan nozzle	30°	M7.676.642.xx.40	○	○	-	-	1.6	2.83	3.46	4.00	4.47	6.33	15	15	-	-
	30°	M7.676.722.xx.40	○	○	-	-	2.1	4.46	5.46	6.30	7.04	9.96	15	15	-	-
	30°	M7.676.762.xx.40	○	○	-	-	2.3	5.66	6.93	8.00	8.94	12.65	15	15	-	-
	30°	M7.676.802.xx.40	○	○	-	-	2.6	7.07	8.66	10.00	11.18	15.81	15	15	-	-
	30°	M7.676.842.xx.40	○	○	-	-	3.0	8.84	10.82	12.50	13.97	19.76	15	15	-	-
	30°	M7.676.882.xx.40	○	○	-	-	3.4	11.31	13.86	16.00	17.89	25.30	15	15	10	8
	30°	M7.676.922.xx.40	○	○	-	-	4.1	14.14	17.32	20.00	22.36	31.62	15	15	10	8
	30°	M7.676.962.xx.40	○	○	-	-	4.2	17.68	21.65	25.00	27.95	39.53	15	15	10	8
	30°	M7.677.002.xx.40	○	-	-	-	4.7	22.27	27.82	31.50	35.22	49.81	15	-	-	-
1 Flat fan nozzle	60°	M7.676.644.xx.40			-	-	1.6	2.83	3.46	4.00	4.47	6.33	15	15	-	-
	60°	M7.676.724.xx.40			-	-	2.1	4.46	5.46	6.30	7.04	9.96	15	15	-	-
	60°	M7.676.764.xx.40			-	-	2.3	5.66	6.93	8.00	8.94	12.65	15	15	-	-
	60°	M7.676.804.xx.40			-	-	2.6	7.07	8.66	10.00	11.18	15.81	15	15	-	-
	60°	M7.676.844.xx.40			-	-	3.0	8.84	10.82	12.50	13.97	19.76	15	15	-	-
	60°	M7.676.884.xx.40			-	-	3.4	11.31	13.86	16.00	17.89	25.30	15	15	10	8
	60°	M7.676.924.xx.40			-	-	4.1	14.14	17.32	20.00	22.36	31.62	15	15	10	8
	60°	M7.676.964.xx.40			-	-	4.2	17.68	21.65	25.00	27.95	39.53	15	15	10	8
	60°	M7.677.004.xx.40			-	-	4.7	22.27	27.82	31.50	35.22	49.81	15	15	10	8
	60°	M7.677.044.xx.40			-	-	5.5	28.28	34.64	40.00	44.72	63.25	15	15	-	-
	60°	M7.677.084.xx.40			-	-	6.2	35.36	43.30	50.00	55.90	79.06	15	15	-	-

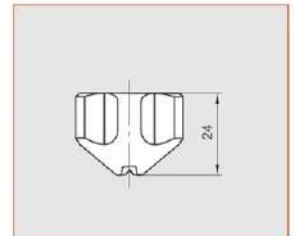

Type	$\Delta$	Ordering no.	Material				Flow rate [l/min] bei p [bar]					Weight [g]				
			8F	8R	E8	53	1.0	1.5	2.0	2.5	5.0	PP/303 SS	PP/316L SS	PP/ceramic	PP	
1 Flat fan nozzle	90°	M7.676.646.xx.40	○	○	-	-	1.6	2.83	3.46	4.00	4.47	6.33	15	15	-	-
		M7.676.726.xx.40	○	○	-	-	2.1	4.46	5.46	6.30	7.04	9.96	15	15	-	-
		M7.676.766.xx.40	○	○	-	-	2.3	5.66	6.93	8.00	8.94	12.65	15	15	-	-
		M7.676.806.xx.40	○	○	-	-	2.6	7.07	8.66	10.00	11.18	15.81	15	15	-	-
		M7.676.846.xx.40	○	○	-	-	3.0	8.84	10.82	12.50	13.97	19.76	15	15	-	-
		M7.676.886.xx.40	○	○	-	-	3.4	11.31	13.86	16.00	17.89	25.30	15	15	-	-
		M7.676.926.xx.40	○	○	-	-	4.1	14.14	17.32	20.00	22.36	31.62	15	15	-	-
		M7.676.966.xx.40	○	○	-	-	4.2	17.68	21.65	25.00	27.95	39.53	15	15	-	-
1 Flat fan nozzle	120°	M7.676.647.xx.40	○	○	-	-	1.6	2.83	3.46	4.00	4.47	6.33	15	15	-	-
		M7.676.727.xx.40	○	○	-	-	2.1	4.46	5.46	6.30	7.04	9.96	15	15	-	-
		M7.676.767.xx.40	○	○	-	-	2.3	5.66	6.93	8.00	8.94	12.65	15	15	-	-
		M7.676.807.xx.40	○	○	-	-	2.6	7.07	8.66	10.00	11.18	15.81	15	15	-	-
		M7.676.847.xx.40	○	○	-	-	3.0	8.84	10.82	12.50	13.97	19.76	15	15	-	-
		M7.676.887.xx.40	○	○	-	-	3.4	11.31	13.86	16.00	17.89	25.30	15	15	-	-
		M7.676.927.xx.40	○	○	-	-	4.1	14.14	17.32	20.00	22.36	31.62	15	15	-	-
		M7.676.967.xx.40	○	○	-	-	4.2	17.68	21.65	25.00	27.95	39.53	15	15	-	-
Blind nozzle	-	M7.067.630.8F.40.01	○	-	-	-	-	-	-	-	-	15	-	-	-	

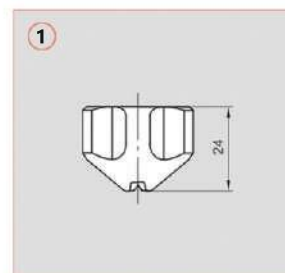

Type	$\Delta$	$\eta$	Ordering no.	Material		Flow rate [l/min] at p [bar]					Weight		
				8R	5E	1.0	1.5	2.0	2.5	5.0	PP/316L SS	PVDF	
1a Tongue type nozzle	90°	35°	M7.676.803.XX.41	○	-	3.4	7.07	8.66	10.00	11.18	15.81	25	-
			M7.676.874.XX.41	○	-	4.2	10.61	12.99	15.00	16.17	23.72	25	-
			M7.676.924.XX.41	○	-	4.7	14.14	17.32	20.00	22.36	31.62	25	-
			M7.677.005.XX.41	○	○	6.0	22.27	27.28	31.50	35.22	49.81	25	11



Example            Type            +    Material-no.    =    Ordering no.  
 for Ordering: M7.676.646.xx.40    +    8R                    =    M7.676.646.8R.40



	Type	Ordering No.	Material		Spigot	Recommended bore	For pipe	Weight [g]
			53	6M				
								P.P.
2a	Ball retainer cap	M.092.080.xx.00.02	○	-				18
2b	Ball retainer cap	M.067.600.xx.40	○	-				18
3	Ball bayonet base	M.067.630.xx.40	○	-				12
4	Ball seat for eyelet clamp no. M.067.631.xx.40.02	M.067.631.xx.40.22	-	○	13.8 mm	14.0-14.3 mm	1 1/4" (40.0-43.0 mm)	9
	M.067.631.xx.40.00.0	M.067.631.xx.40.12	-	○	16.0 mm	16.5-17.0 mm	1 1/4" (40.0-43.0 mm)	11
	M.067.631.xx.40.00.0	M.067.631.xx.40.12	-	○	19.8 mm	20.3-20.8 mm	1 1/4" (40.0-43.0 mm)	13
	Ball seat for eyelet clamp no. M.067.631.xx.50.02	M.067.631.xx.50.22	-	○	13.8 mm	14.0-14.3 mm	1 1/4" (46.0-49.0 mm)	9
	M.067.631.xx.50.00.0	M.067.631.xx.50.12	-	○	16.0 mm	16.5-17.0 mm	1 1/4" (46.0-49.0 mm)	11
	M.067.631.xx.50.00.0	M.067.631.xx.50.12	-	○	19.8 mm	20.3-20.8 mm	1 1/4" (46.0-49.0 mm)	13
5a	Easy Locked	M.067.631.xx.40.00	○	-	-	-	1 1/4" (40.0-43.0 mm)	31
	M.067.631.xx.50.00	M.067.631.xx.50.00	○	-	-	-	1 1/2" (46.0-49.0 mm)	33
5b	Screwed Locked	M.090.023.xx.44.10	○	-	13.8 mm	14.0-14.3 mm	1" (32.0-34.5 mm)	48
		M.090.023.xx.43.10	○	-	16.0 mm	16.5-17.0 mm	1" (32.0-34.5 mm)	48
		M.090.033.xx.44.10	○	-	13.8 mm	14.0-14.3 mm	1 1/4" (40.0-43.0 mm)	50
		M.090.033.xx.43.10	○	-	16.0 mm	16.5-17.0 mm	1 1/4" (40.0-43.0 mm)	50
		M.090.033.xx.40.10	○	-	20.0 mm	20.5-21.0 mm	1 1/4" (40.0-43.0 mm)	50
		M.090.043.xx.44.10	○	-	13.8 mm	14.0-14.3 mm	1 1/2" (46.0-49.0 mm)	52
		M.090.043.xx.43.10	○	-	16.0 mm	16.5-17.0 mm	1 1/2" (46.0-49.0 mm)	52
M.090.043.xx.40.10	○	-	20.0 mm	20.5-21.0 mm	1 1/2" (46.0-49.0 mm)	52		
5c	Single clamp	M.092.080.xx.00	○	-	16.3 mm	16.5-17.0 mm	1" (32.0-34.5 mm)	36
		M.092.081.xx.00	○	-	16.3 mm	16.5-17.0 mm	1 1/4" (40.0-43.0 mm)	38
		M.092.082.xx.00	○	-	16.3 mm	16.5-17.0 mm	1 1/2" (46.0-49.0 mm)	40
		M.092.083.xx.00	○	-	16.3 mm	16.5-17.0 mm	2" (58.0-62.0 mm)	42

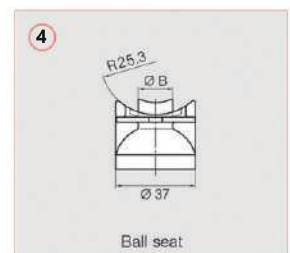
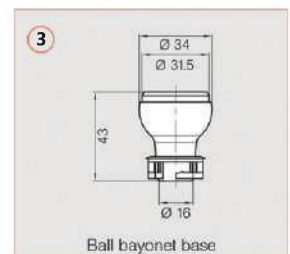
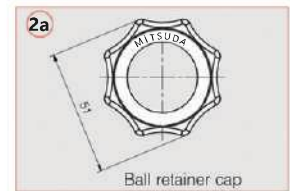

**Example for ordering:** Type **M.092.080.xx.02.00** + Material-no. **53** = Ordering no. **M.092.080.53.00.02**

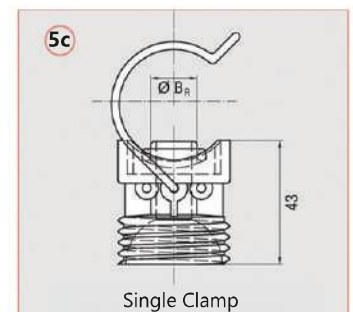
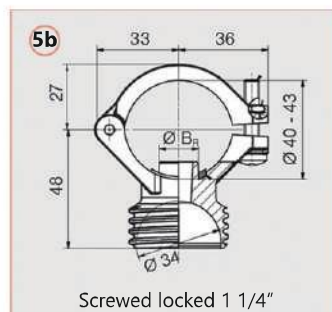
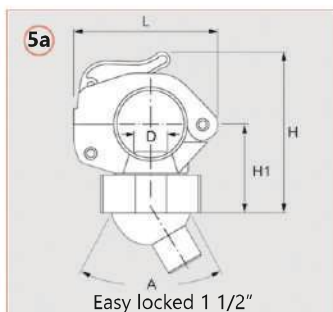

## SETS

- Existing of
- Nozzle
- Single or double clamp for 1-1
- Ball retainer cap



PICTURE	ORDERING NO	NOZZLE COLOUR		V (L/MIN)-P(BAR)				
				0,5 BAR	1,0 BAR	1,5 BAR	2,0 BAR	2,5 BAR
	M1.676.514.53.31	BEJ	60	0,95	1,34	1,70	1,90	2,10
	M1.676.644.53.31	ORANGE	60	2,00	2,83	3,15	4,00	4,45
	M1.676.724.53.31	GREY	60	3,15	4,45	5,45	6,30	7,09
	M1.676.764.53.31	BROWN	60	4,00	5,66	6,93	8,00	8,94
	M1.676.804.53.31	LILAC	60	5,00	7,07	8,66	10,00	11,18
	M1.676.844.53.31	YELLOW	60	6,25	8,84	10,83	12,50	13,98
	M1.676.884.53.31	RED	60	8,00	11,31	13,85	16,00	17,89
	M1.676.904.53.31	BLUE	60	9,10	12,87	15,76	18,20	20,35
	M1.676.924.53.31	PINK	60	10,00	14,14	17,30	20,00	22,70
	M1.676.944.53.31	GREEN	60	12,50	17,68	22,00	25,00	28,60

## NOZZLE

PICTURE	ORDERING NO	NOZZLE COLOUR		V (L/MIN)-P(BAR)				
				0,5 BAR	1,0 BAR	1,5 BAR	2,0 BAR	2,5 BAR
	M1.676.514.53.00.01	BEJ	60	0,95	1,34	1,70	1,90	2,10
	M1.676.644.53.00.01	ORANGE	60	2,00	2,83	3,15	4,00	4,45
	M1.676.724.53.00.01	GREY	60	3,15	4,45	5,45	6,30	7,09
	M1.676.764.53.00.01	BROWN	60	4,00	5,66	6,93	8,00	8,94
	M1.676.804.53.00.01	LILAC	60	5,00	7,07	8,66	10,00	11,18
	M1.676.844.53.00.01	YELLOW	60	6,25	8,84	10,83	12,50	13,98
	M1.676.884.53.00.01	RED	60	8,00	11,31	13,85	16,00	17,89
	M1.676.904.53.00.01	BLUE	60	9,10	12,87	15,76	18,20	20,35
	M1.676.924.53.00.01	PINK	60	10,00	14,14	17,30	20,00	22,70
	M1.676.944.53.00.01	GREEN	60	12,50	17,68	22,00	25,00	28,60
	M1.092.080.53.00.01	BLACK	BLIND NOZZLE					

Easy installation with clamp  
 Easy alignment and cleaning  
 Without using extra tools  
 All over rotating by 30 degree.  
 Treatments:  
 Phosphating in surface treatment,  
 cleaning, degreasing.

Materials:  
 Clamp: Stainless steel 301 SS  
 Sealing: EPDM  
 Cylinder pin, screw and screw  
 unit: 316 SS.  
 Body, ball retaining cap: PP,  
 reinforced  
 Nozzle, ball joint: PP

## Sets

### Existing of

- Nozzle
- Single clamp for 1/4" pipe
- Ball retaining cap

Ordering no.	Nozzle colour		$\dot{V}$ [l/min]				
			p [bar]				
			0.5	1.0	1.5	2.0	2.5
M1.676.724.53.31	grey	60°	3.15	4.45	5.45	6.30	7.09
M1.676.764.53.31	brown	60°	4.00	5.66	6.93	8.00	8.94
M1.676.804.53.31	lilac	60°	5.00	7.07	8.66	10.00	11.18
M1.676.844.53.31	yellow	60°	6.25	8.84	10.83	12.50	13.98
M1.676.884.53.31	red	60°	8.00	11.31	13.85	16.00	17.89
M1.676.904.53.31	blue	60°	9.10	12.87	15.76	18.20	20.35
M1.676.924.53.31	green	60°	10.00	14.14	17.32	20.00	22.36

### Existing of

- Ball joint
- Single clamp for 1/4" pipe
- Ball retaining cap

Ordering no.	Ball colour	Nozzle connection	For nozzle series
M.092.081.53.AB	beige	1/8 BSPP	460, 490, 632, 686, 544
M.092.081.53.AD	beige	1/4 BSPP	422, 460, 490, 544, 632, 686
M.092.081.53.AF	beige	3/8 BSPP	422, 460, 490, 632, 686, 688
M.092.081.53.AH	beige	1/2 BSPP	422, 460, 490, 632, 686

## Components

### 1 Nozzle

Ordering no.	Colour		$\dot{V}$ [l/min]				
			p [bar]				
			0.5	1.0	1.5	2.0	2.5
M1.626.724.53.30.01	grey	60°	3.15	4.45	5.45	6.30	7.04
M1.676.764.53.00.01	brown	60°	4.00	5.66	6.93	8.00	8.94
M1.676.804.53.00.01	lilac	60°	5.00	7.07	8.66	10.00	11.18
M1.676.844.53.00.01	yellow	60°	6.25	8.84	10.83	12.50	13.98
M1.676.884.53.00.01	red	60°	8.00	11.31	13.85	16.00	17.89
M1.676.904.53.00.01	blue	60°	9.10	12.87	15.67	18.20	20.35
M1.676.924.53.00.01	green	60°	10.00	14.14	17.32	20.00	22.36
M1.092.080.53.00.01	grey		Blind nozzle				

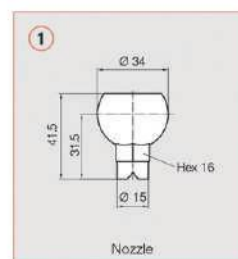
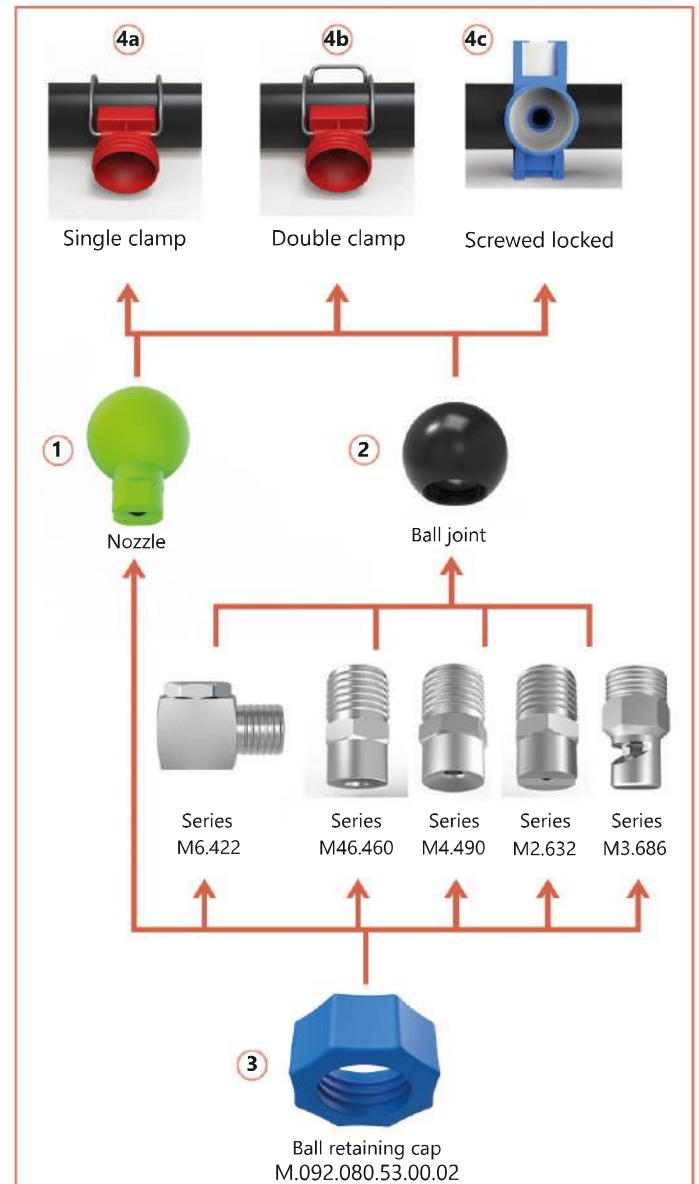

## 2 Ball joint

Ordering no.	Colour	Nozzle connection	L [mm]	For nozzle series
M.092.080.53.AB.01	beige	1/8 BSPP	28.4	460,490,544,632,686
M.092.080.53.AD.01	beige	1/4 BSPP	32.4	422,460,490,544,632,686
M.092.080.53.AF.01	beige	3/8 BSPP	31.4	422,460,490,632,686,688
M.092.080.53.AH.01	beige	1/2 BSPP	33.0	422,460,490,632,686

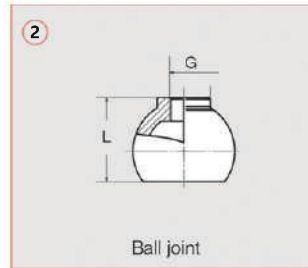

## 3 Ball retainer cap

Ordering no.
M.092.080.53.00.02

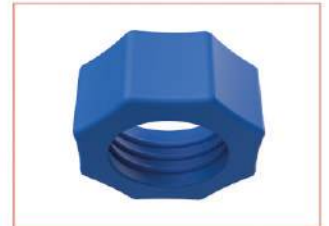
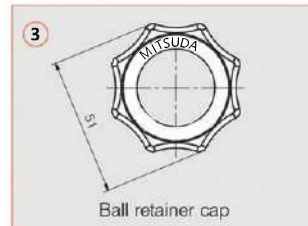

## 4a Single clamp

Ordering no.	Spigot-Ø Br	Recommended bore-Ø	For pipe-Ø
M.092.080.53.00	16.3 mm	16.5-17.0 mm	1" (32.0-34.5 mm)
M.092.081.53.00	16.3 mm	16.5-17.0 mm	1 1/4" (40.0-43.0 mm)
M.092.082.53.00	16.3 mm	16.5-17.0 mm	1 1/2" (46.0-49.0 mm)
M.092.083.53.00	16.3 mm	16.5-17.0 mm	2" (58.0-62.0 mm)

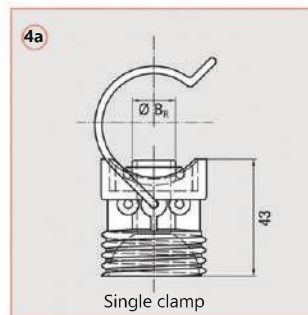

## 4b Double clamp

Ordering no.	Spigot-Ø Br	Recommended bore-Ø	For pipe-Ø
M.092.090.53.00	16.3 mm	16.5-17.0 mm	1" (32.0-34.5 mm)
M.092.091.53.00	16.3 mm	16.5-17.0 mm	1 1/4" (40.0-43.0 mm)
M.092.092.53.00	16.3 mm	16.5-17.0 mm	1 1/2" (46.0-49.0 mm)
M.092.093.53.00	16.3 mm	16.5-17.0 mm	2" (58.0-62.0 mm)
M.092.090.52.00	14.2 mm	14.5-15.0 mm	1" (32.0-34.5 mm)
M.092.091.52.00	14.2 mm	14.5-15.0 mm	1 1/4" (40.0-43.0 mm)
M.092.092.52.00	14.2 mm	14.5-15.0 mm	1 1/2" (46.0-49.0 mm)
M.092.093.52.00	14.2 mm	14.5-15.0 mm	2" (58.0-62.0 mm)
M.092.090.54.00	20.3 mm	20.5-21.0 mm	1" (32.0-34.5 mm)
M.092.091.54.00	20.3 mm	20.5-21.0 mm	1 1/4" (40.0-43.0 mm)
M.092.092.54.00	20.3 mm	20.5-21.0 mm	1 1/2" (46.0-49.0 mm)
M.092.093.54.00	20.3 mm	20.5-21.0 mm	2" (58.0-62.0 mm)

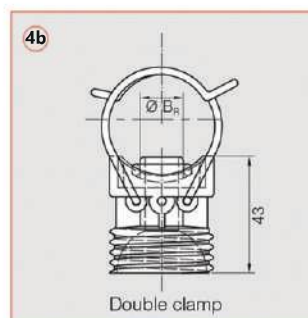

## 4c Screwed Locked

Ordering no.	Spigot-Ø Br	Recommended bore-Ø	For pipe-Ø
M.090.023.53.43.10	16 mm	16.5-17.0 mm	1" (32.0-34.5 mm)
M.090.033.53.43.10	16 mm	16.5-17.0 mm	1 1/4" (40.0-43.0 mm)
M.090.043.53.43.10	16 mm	16.5-17.0 mm	1 1/4" (40.0-43.0 mm)

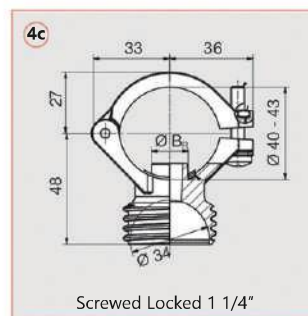

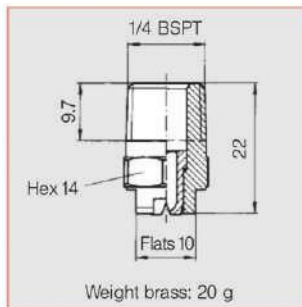
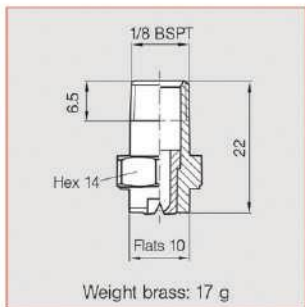

Mitsuda Flat fan nozzles are designed with very narrow spray depth, high precision spray angle and precise flow rate. These features enable the series appropriate for all complicated cleaning tasks. Thanks to parabolic distribution of liquid, spraying pipes with those nozzles ensure an even liquid distribution. Series with conical, self-sealing thread connection.

Applications: Surface treatment, coating, belt cleaning, filter cleaning, lubrication.

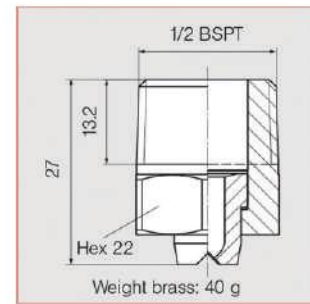
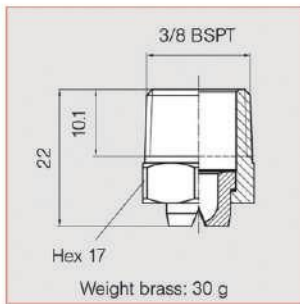

Spray angle	Ordering no.								A Ø [mm]	E Ø [mm]	$\dot{V}$ [l/min]								Spray width B at p=2 bar		
	Type	Material no.				Code					p [bar]										
		303SS/304SS	316TiSS/316L SS	Brass	PVDF	1/8 BSPT	1/4 BSPT	3/8 BSPT			1/2 BSPT	0.5	1.0	2.0	3.0	5.0	7.0	10.0	H=250 mm	H=500 mm	
20°	M2.632.301	○	○	○	○	CA	CC	-	-	0.70	0.60	0.16*	0.23*	0.32	0.39	0.51	0.60	0.72	65	120	
	M2.632.361	○	○	○	○	CA	CC	-	-	1.00	0.80	0.31*	0.44*	0.63	0.77	1.00	1.18	1.40	70	130	
	M2.632.441	○	○	○	○	CA	CC	-	-	1.35	1.10	0.62*	0.88	1.25	1.53	1.98	2.34	2.80	75	145	
	M2.632.481	○	○	○	○	CA	CC	-	-	1.50	1.20	0.80*	1.13	1.60	1.96	2.53	2.99	3.58	75	150	
30°	M2.632.302	○	○	○	○	CA	CC	-	-	0.60	0.50	0.16*	0.23*	0.32	0.39	0.51	0.60	0.72	120	235	
	M2.632.362	○	○	○	○	CA	CC	-	-	1.00	0.70	0.31*	0.44*	0.63	0.77	1.00	1.18	1.40	120	235	
	M2.632.402	○	○	○	○	CA	CC	-	-	1.20	0.90	0.62*	0.71	1.00	1.23	1.58	1.87	2.24	120	235	
	M2.632.482	○	○	○	○	CA	CC	-	-	1.50	1.10	0.80*	1.13	1.60	1.96	2.53	2.99	3.58	120	235	
	M2.632.562	○	○	○	○	CA	CC	-	-	2.00	1.50	1.25	1.17	2.50	3.06	3.95	4.68	5.59	120	235	
	M2.632.642	○	○	○	-	-	CC	-	-	2.50	1.80	2.00	2.83	4.00	4.90	6.33	7.48	8.94	120	240	
	M2.632.722	○	○	○	-	-	CC	-	-	3.00	2.40	3.15	4.46	6.30	7.72	9.96	11.79	14.09	125	240	
	M2.632.762	○	○	○	-	-	CC	-	-	3.50	2.70	4.00	5.66	8.00	9.80	12.65	14.97	17.89	125	240	
	M2.632.802	○	○	○	-	-	CC	-	-	4.00	3.00	5.00	7.07	10.00	12.25	15.81	18.71	22.36	130	250	

Example      Type   + Material no.   + Code   = Ordering no.  
for ordering: M2.632.301 + 16                      + CA           = M2.632.301.16.CA

Spray Angle	Ordering no.								A ∅ [mm]	E ∅ [mm]	V̇ [l/min]							Spray width B at p = 2 bar		
	Type	Material no.				Code					p [bar]									
		16	17	30	SE							0.5	1.0	2.0	3.0	5.0	7.0			10.0
	303 SS/304 SS	316Ti SS/ 316L SS	Brass	PVDF	1/8 BSPT	1/4 BSPT	3/8 BSPT	1/2 BSPT												250 mm
90°	M2.632.216	○	○	○	-	CA	CC	-	-	0.40	0.20	-	0.08*	0.11	0.14	0.18	0.21	0.25	370	700
	M2.632.276	○	○	○	-	CA	CC	-	-	0.60	0.30	0.11*	0.16*	0.22	0.27	0.35	0.41	0.49	375	720
	M2.632.306	○	○	○	○	CA	CC	-	-	0.70	0.40	0.16*	0.23*	0.32	0.39	0.51	0.60	0.72	380	740
	M2.632.336	○	○	○	○	CA	CC	-	-	0.90	0.50	0.22*	0.32*	0.45	0.55	0.71	0.84	1.01	415	800
	M2.632.366	○	○	○	○	CA	CC	-	-	1.00	0.50	0.31*	0.44*	0.63	0.77	1.00	1.18	1.41	420	810
	M2.632.406	○	○	○	○	CA	CC	-	-	1.20	0.70	0.50*	0.71	1.00	1.23	6.33	1.87	2.24	430	820
	M2.632.446	○	○	○	○	CA	CC	-	-	1.35	0.80	0.62*	0.88	1.25	1.53	7.51	2.34	2.80	435	830
	M2.632.486	○	○	○	○	CA	CC	-	-	1.50	0.80	0.80*	1.13	1.60	1.96	9.96	2.99	3.58	440	835
	M2.632.516	○	○	○	○	CA	CC	-	-	1.65	0.90	0.95*	1.34	1.90	2.33	12.65	3.56	4.25	440	840
	M2.632.566	○	○	○	○	CA	CC	-	-	2.00	1.10	1.25	1.77	2.50	3.06	3.95	4.68	5.59	445	850
	M2.632.606	○	○	○	○	CA	CC	-	-	2.20	1.20	1.58	2.23	3.15	3.86	4.98	5.89	7.04	450	860
	M2.632.646	○	○	○	○	-	CC	CE	-	2.50	1.30	2.00	2.83	4.00	4.90	6.33	7.48	8.94	455	865
	M2.632.676	○	○	○	○***	-	CC	CE	-	2.70	1.40	2.38	3.36	4.75	5.82	7.51	8.89	10.62	465	875
	M2.632.726	○	○	○	○***	-	CC	CE	-	3.00	1.70	3.15	4.46	6.30	7.72	9.96	46.77	14.09	470	885
	M2.632.766	○	○	○	○***	-	CC	CE	-	3.50	1.90	4.00	5.66	8.00	9.80	12.65	14.97	17.89	475	890
	M2.632.806	○	○***	○	○***	-	CC	-	CG	4.00	2.40	5.00	7.07	10.00	12.25	15.81	18.71	22.36	480	900
M2.632.846	○	○***	○	○***	-	CC	-	CG	4.50	2.40	6.25	8.84	12.50	15.31	19.76	23.39	27.95	480	900	
M2.632.886	○	○***	○	○***	-	CC	-	CG	5.00	3.10	8.00	11.31	16.00	19.60	25.30	29.93	35.78	480	910	
M2.632.926	○	○	○	-	-	-	-	CG	5.50	3.60	10.00	14.14	20.00	24.50	31.62	37.42	44.72	525	1020	
M2.632.966	○	○	○	-	-	-	-	CG	6.00	3.90	12.50	17.68	25.00	30.62	39.53	46.77	55.90	525	1020	
120°	M2.632.187	○	-	○	-	CA	CC	-	-	0.35	0.20	-	0.06*	0.08	0.10	0.13	0.15	0.18	630	1200
	M2.632.217	○	-	○	-	CA	CC	-	-	0.40	0.20	-	0.08*	0.11	0.14	0.18	0.21	0.25	640	1210
	M2.632.247	○	-	○	-	CA	CC	-	-	0.50	0.20	-	0.12*	0.16	0.20	0.26	0.30	0.36	650	1230
	M2.632.277	○	-	○	-	CA	CC	-	-	0.60	0.30	-	0.16*	0.22	0.27	0.35	0.41	0.49	660	1250
	M2.632.307	○	○	○	○	CA	CC	-	-	0.70	0.30	0.16*	0.23*	0.32	0.39	0.51	0.60	0.72	660	1250
	M2.632.337	○	○	○	○	CA	CC	-	-	0.90	0.40	0.22*	0.32*	0.45	0.55	0.71	0.84	1.01	670	1270
	M2.632.367	○	○	○	○	CA	CC	-	-	1.00	0.50	0.31*	0.71	0.63	0.77	1.00	1.18	1.41	670	1270
	M2.632.407	○	○	○	○	CA	CC	-	-	1.20	0.60	0.50*	0.88	1.00	1.23	1.58	1.87	2.24	670	1270
	M2.632.447	○	○	○	○	CA	CC	-	-	1.35	0.60	0.62*	1.13	1.25	1.53	1.98	2.34	2.80	675	1270
	M2.632.487	○	○	○	○	CA	CC	-	-	1.50	0.60	0.80*	1.34	1.60	1.96	2.53	2.99	3.58	680	1275
	M2.632.517	○	○	○	○	CA	CC	-	-	1.65	0.90	0.95*	1.77	1.90	2.33	3.00	3.56	4.25	685	1280
	M2.632.567	○	○	○	○	CA	CC	-	-	2.00	0.90	1.25	2.23	2.50	3.06	3.95	4.68	5.59	690	1285
	M2.632.607	○	○	○	○	CA	CC	-	-	2.20	1.10	1.58	2.83	3.15	3.86	4.98	5.89	7.04	700	1300
	M2.632.647	○	○	○	-	-	CC	CE	-	2.50	1.30	2.00	3.36	4.00	4.90	6.33	7.48	8.94	700	1300
	M2.632.677	○	○	○	○***	-	CC	CE	-	2.70	1.40	2.38	4.46	4.75	5.82	7.51	8.89	10.62	720	1330
	M2.632.727	○	○	○	○***	-	CC	CE	-	3.00	1.60	3.15	5.66	6.30	7.72	9.96	11.79	14.09	740	1360
	M2.632.767	○	○	○	○***	-	CC	CE	-	3.50	1.70	4.00	7.07	8.00	9.80	12.65	14.97	17.89	760	1400
	M2.632.807	○	○***	○	-	-	CC	-	CG	4.00	2.00	5.00	7.07	10.00	12.25	15.81	18.71	22.36	790	1450
	M2.632.847	○***	○***	○***	○***	-	CC	-	CG	4.50	2.30	6.25	8.84	12.50	15.31	19.76	23.39	27.95	790	1450
M2.632.887	○	○	○	-	-	-	-	CG	5.00	2.60	8.00	11.31	16.00	19.90	25.30	29.93	35.78	800	1460	
M2.632.927	○	○	○	-	-	-	-	CG	5.50	2.90	10.00	14.14	20.00	24.50	31.62	37.42	44.72	800	1460	

**Example** Type + Material no. + Code = Ordering no.  
 for ordering: M2.632.216 + 16 + CA = M2.632.216.16.CA





This series provides cost efficiency in standard cleaning and rinsing applications.  
 Series with uniform flat fan, conical, self-sealing thread connection. It can be used with spray pipes. Manufactured upon order for quantities 250 or more.  
 Applications:  
 Standard cleaning and rinsing treatments.

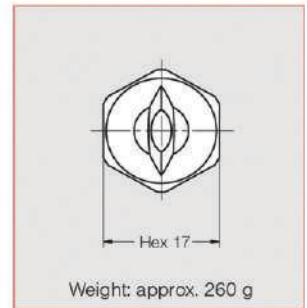
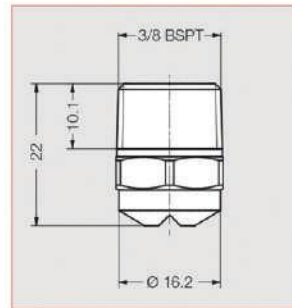
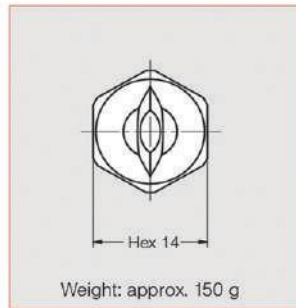
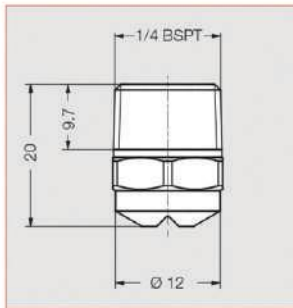
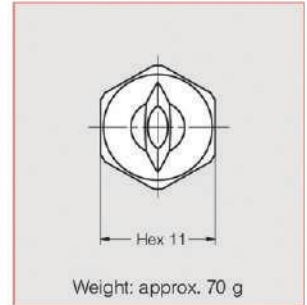
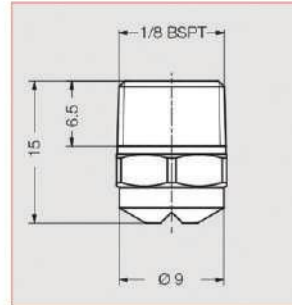

Spray angle $\Delta$	Ordering no.					A $\varnothing$ [mm]	E $\varnothing$ [mm]	$\dot{V}$ [l/min]							Spray width B at p = 2 bar	
	Type	Mat no.	Code					p [bar]								
			1C	304 SS	1/8 BSPT			1/4 BSPT	3/8 BSPT	0.5	1.0	2.0	3.0	5.0	7.0	10.0
45°	M8.650.483	○	CA	CC	-	1.50	1.10	0.80*	1.13	1.60	1.96	2.53	2.99	3.58	180	340
	M8.650.563	○	CA	CC	-	2.00	1.40	1.25	1.77	2.50	3.06	3.95	4.68	5.59	185	355
	M8.650.603	○	CA	CC	-	2.20	1.60	1.58	2.23	3.15	3.86	4.98	5.89	7.04	195	370
	M8.650.643	○	CA	CC	-	2.50	1.80	2.00	2.83	4.00	4.90	6.33	7.48	8.94	195	370
	M8.650.673	○	CA	CC	-	2.70	2.00	2.83	3.36	4.75	5.82	7.51	8.89	10.62	200	375
	M8.650.723	○	CA	CC	-	3.00	2.40	3.15	4.46	6.30	7.72	9.96	11.79	14.09	200	375
	M8.650.763	○	CA	CC	-	3.50	2.60	4.00	5.66	8.00	9.80	12.65	14.97	17.89	200	380
	M8.650.803	○	-	CC	-	4.00	3.00	5.00	7.07	10.00	12.25	15.81	18.71	22.36	205	385
	M8.650.843	○	-	CC	CE	4.50	3.40	6.25	8.84	12.50	15.31	19.76	23.39	27.95	205	385
	M8.650.883	○	-	CC	CE	5.00	3.80	8.00	11.31	16.00	19.60	25.30	29.93	35.78	220	440
	M8.650.923	○	-	CC	CE	5.50	4.20	10.00	14.14	20.00	24.50	31.62	37.42	44.72	220	440
	M8.650.963	○	-	-	CE	6.00	4.40	12.50	17.68	25.00	30.62	39.53	46.77	55.90	220	440
	M8.650.993	○	-	-	CE	6.50	4.80	15.00	21.21	30.00	36.74	47.43	56.12	67.08	220	440
	M8.651.003	○	-	-	CE	7.00	5.20	15.75	22.27	31.50	38.57	49.80	58.92	70.43	220	440
	M8.651.043	○	-	-	CE	8.00	5.90	20.00	28.28	40.00	48.99	63.25	74.83	89.44	220	440

Example      Type    + Material no.    + Code = Ordering no.  
 for ordering: M8.650.483 + 1C                      + CA                      = M8.650.483.1C.CA

 Spray angle	Ordering no.					A ∅ [mm]	E ∅ [mm]	V̇ [l/min]							Spray width B at p = 2 bar	
	Type	Mat no.	Code					p [bar]							 H= 250 mm    H= 500 mm	
			1C	1/8 BSPT	1/4 BSPT			3/8 BSPT	0.5	1.0	2.0	3.0	5.0	7.0		
															304 SS	
45°	M8.650.484	○	CA	CC	-	1.50	1.10	0.80*	1.13	1.60	1.96	2.53	2.99	3.58	260	510
	M8.650.564	○	CA	CC	-	2.00	1.40	1.25	1.77	2.50	3.06	3.95	4.68	5.59	280	535
	M8.650.604	○	CA	CC	-	2.20	1.60	1.58	2.23	3.15	3.86	4.98	5.89	7.04	290	550
	M8.650.644	○	CA	CC	-	2.50	1.80	2.00	2.83	4.00	4.90	6.33	7.48	8.94	295	565
	M8.650.674	○	CA	CC	-	2.70	2.00	2.83	3.36	4.75	5.82	7.51	8.89	10.62	300	575
	M8.650.724	○	CA	CC	-	3.00	2.40	3.15	4.46	6.30	7.72	9.96	11.79	14.09	305	590
	M8.650.764	○	CA	CC	-	3.50	2.60	4.00	5.66	8.00	9.80	12.65	14.97	17.89	310	595
	M8.650.804	○	-	CC	-	4.00	3.00	5.00	7.07	10.00	12.25	15.81	18.71	22.36	310	595
	M8.650.844	○	-	CC	CE	4.50	3.40	6.25	8.84	12.50	15.31	19.76	23.39	27.95	310	590
	M8.650.884	○	-	CC	CE	5.00	3.80	8.00	11.31	16.00	19.60	25.30	29.93	35.78	300	570
	M8.650.924	○	-	CC	CE	5.50	4.20	10.00	14.14	20.00	24.50	31.62	37.42	44.72	330	630
	M8.650.964	○	-	-	CE	6.00	4.40	12.50	17.68	25.00	30.62	39.53	46.77	55.90	330	630
	M8.650.994	○	-	-	CE	6.50	4.80	15.00	21.21	30.00	36.74	47.43	56.12	67.08	330	630
	M8.651.004	○	-	-	CE	7.00	5.20	15.75	22.27	31.50	38.57	49.80	58.92	70.43	330	630
M8.651.044	○	-	-	CE	8.00	5.90	20.00	28.28	40.00	48.99	63.25	74.83	89.44	340	640	
90°	M8.650.486	○	CA	CC	-	1.50	1.10	0.80*	1.13	1.60	1.96	2.53	2.99	3.58	440	835
	M8.650.566	○	CA	CC	-	2.00	1.40	1.25	1.77	2.50	3.06	3.95	4.68	5.59	445	850
	M8.650.606	○	CA	CC	-	2.20	1.60	1.58	2.23	3.15	3.86	4.98	5.89	7.04	450	860
	M8.650.646	○	CA	CC	-	2.50	1.80	2.00	2.83	4.00	4.90	6.33	7.48	8.94	455	865
	M8.650.676	○	CA	CC	-	2.70	2.00	2.83	3.36	4.75	5.82	7.51	8.89	10.62	465	875
	M8.650.726	○	CA	CC	-	3.00	2.40	3.15	4.46	6.30	7.72	9.96	11.79	14.09	470	885
	M8.650.766	○	CA	CC	-	3.50	2.60	4.00	5.66	8.00	9.80	12.65	14.97	17.89	475	890
	M8.650.806	○	-	CC	-	4.00	3.00	5.00	7.07	10.00	12.25	15.81	18.71	22.36	480	900
	M8.650.846	○	-	CC	CE	4.50	3.40	6.25	8.84	12.50	15.31	19.76	23.39	27.95	480	900
	M8.650.886	○	-	CC	CE	5.00	3.80	8.00	11.31	16.00	19.60	25.30	29.93	35.78	480	910
	M8.650.926	○	-	CC	CE	5.50	4.20	10.00	14.14	20.00	24.50	31.62	37.42	44.72	525	1020
	M8.650.966	○	-	-	CE	6.00	4.40	12.50	17.68	25.00	30.62	39.53	46.77	55.90	525	1020
	M8.650.996	○	-	-	CE	6.50	4.80	15.00	21.21	30.00	36.74	47.43	56.12	67.08	525	1020
	M8.651.006	○	-	-	CE	7.00	5.20	15.75	22.27	31.50	38.57	49.80	58.92	70.43	525	1020
M8.651.046	○	-	-	CE	8.00	5.90	20.00	28.28	40.00	48.99	63.25	74.83	89.44	525	1020	
120°	M8.650.487	○	CA	CC	-	1.50	1.10	0.80*	1.13	1.60	1.96	2.53	2.99	3.58	680	1275
	M8.650.567	○	CA	CC	-	2.00	1.40	1.25	1.77	2.50	3.06	3.95	4.68	5.59	690	1285
	M8.650.607	○	CA	CC	-	2.20	1.60	1.58	2.23	3.15	3.86	4.98	5.89	7.04	700	1300
	M8.650.647	○	CA	CC	-	2.50	1.80	2.00	2.83	4.00	4.90	6.33	7.48	8.94	700	1300
	M8.650.677	○	CA	CC	-	2.70	2.00	2.83	3.36	4.75	5.82	7.51	8.89	10.62	720	1330
	M8.650.727	○	CA	CC	-	3.00	2.40	3.15	4.46	6.30	7.72	9.96	11.79	14.09	740	1360
	M8.650.767	○	CA	CC	-	3.50	2.60	4.00	5.66	8.00	9.80	12.65	14.97	17.89	760	1400
	M8.650.807	○	-	CC	-	4.00	3.00	5.00	7.07	10.00	12.25	15.81	18.71	22.36	790	1450
	M8.650.847	○	-	CC	CE	4.50	3.40	6.25	8.84	12.50	15.31	19.76	23.39	27.95	790	1450
	M8.650.887	○	-	CC	CE	5.00	3.80	8.00	11.31	16.00	19.60	25.30	29.93	35.78	800	1460
	M8.650.927	○	-	CC	CE	5.50	4.20	10.00	14.14	20.00	24.50	31.62	37.42	44.72	800	1460
	M8.650.967	○	-	-	CE	6.00	4.40	12.50	17.68	25.00	30.62	39.53	46.77	55.90	800	1460
	M8.650.997	○	-	-	CE	6.50	4.80	15.00	21.21	30.00	36.74	47.43	56.12	67.08	800	1460
	M8.651.007	○	-	-	CE	7.00	5.20	15.75	22.27	31.50	38.57	49.80	58.92	70.43	800	1460
M8.651.047	○	-	-	CE	8.00	5.90	20.00	28.28	40.00	48.99	63.25	74.83	89.44	800	1460	

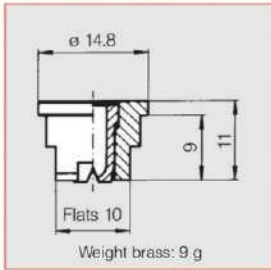

Alignment with retaining nut  
 Simple nozzle changing and jet alignment  
 Even and parabolic liquid distribution  
 Spraying pipes with those nozzles ensure an even liquid distribution.  
 Applications: Surface treatment, coating, belt cleaning, filter cleaning, lubricating.

Spray angle	Ordering no.				A Ø [mm]	E Ø [mm]	V̇ [l/min]						Spray width B at p = 2 bar		
	Type	Material no.					p [bar]								
		16	17 <sup>3)</sup>	30			5E								
		303 SS	316Ti SS/ 316L SS	Brass			PVDF	0.5	1.0	2.0	3.0	5.0	10.0	H=250 mm	H=500 mm
20°	M9.652.301	○	○	○	○	0.70	0.60	0.16*	0.23*	0.32	0.39	0.51	0.72	65	125
	M9.652.361	○	○	○	○	1.00	0.80	0.31*	0.44*	0.63	0.77	1.00	1.40	65	125
	M9.652.441	○	○	○	○	1.35	1.10	0.62*	0.88	1.25	1.53	1.98	2.80	65	125
	M9.652.481	○	○	○	○	1.50	1.20	0.80*	1.13	1.60	1.96	2.53	3.58	65	125
30°	M9.652.302	○	○	○	○	0.60	0.50	0.16*	0.23*	0.32	0.39	0.51	0.72	115	230
	M9.652.362	○	○	○	○	1.00	0.70	0.31*	0.44*	0.63	0.77	1.00	1.40	115	230
	M9.652.402	○	○	○	○	1.20	0.90	0.50*	0.71	1.00	1.23	1.58	2.24	115	230
	M9.652.482	○	○	○	○	1.50	1.10	0.80*	1.13	1.60	1.96	2.53	3.58	115	230
	M9.652.562	○	○	○	○	2.00	1.50	1.25	1.77	2.50	3.06	3.95	5.59	115	230
	M9.652.642	○	○	○	-	2.50	1.80	2.00	2.83	4.00	4.90	6.33	8.94	120	230
	M9.652.722	○	○	○	-	3.00	2.40	3.15	4.46	6.30	7.72	9.96	14.09	120	235
	M9.652.762	○	○	○	-	3.50	2.70	4.00	5.66	8.00	9.80	12.65	17.89	120	235
	M9.652.802	○	○	○	-	4.00	3.10	5.00	7.07	10.00	12.25	15.81	22.36	120	240
45°	M9.652.303	○	○	○	-	0.70	0.50	0.16*	0.23*	0.32	0.39	0.51	0.72	115	230
	M9.652.363	○	○	○	○	1.00	0.70	0.31*	0.44*	0.63	0.77	1.00	1.40	115	230
	M9.652.403	○	○	○	○	1.20	0.90	0.50*	0.71	1.00	1.23	1.58	2.24	115	230
	M9.652.483	○	○	○	○	1.50	1.10	0.80*	1.13	1.60	1.96	2.53	3.58	115	230
	M9.652.563	○	○	○	○	2.00	1.50	1.25	1.77	2.50	3.06	3.95	5.59	115	230
	M9.652.643	○	○	○	-	2.50	1.80	2.00	2.83	4.00	4.90	6.33	8.94	120	230
	M9.652.723	○	○	○	-	3.00	2.40	3.15	4.46	6.30	7.72	9.96	14.09	120	235
	M9.652.763	○	○	○	-	3.50	2.70	4.00	5.66	8.00	9.80	12.65	17.89	120	235
	M9.652.803	○	○	○	-	4.00	3.10	5.00	7.07	10.00	12.25	15.81	22.36	120	240
60°	M9.652.304	○	○	○	○	0.70	0.40	0.16*	0.23*	0.32	0.39	0.51	0.72	275	525
	M9.652.334	○	○	○	○	0.90	0.50	0.22*	0.32*	0.45	0.55	0.71	1.01	275	525
	M9.652.364	○	○	○	○	1.00	0.60	0.31*	0.44*	0.63	0.77	1.00	1.40	275	525
	M9.652.404	○	○	○	○	1.20	0.80	0.50*	0.71	1.00	1.23	1.58	2.24	275	525
	M9.652.444	○	○	○	○	1.35	0.90	0.62*	0.88	1.25	1.53	1.98	2.80	280	530
	M9.652.484	○	○	○	○	1.50	1.00	0.80*	1.13	1.60	1.96	2.53	3.58	280	530
	M9.652.514	○	○	○	○	1.65	1.10	0.95*	1.34	1.90	2.33	3.00	4.25	280	530
	M9.652.564	○	○	○	○	2.00	1.30	1.25	1.77	2.50	3.06	3.95	5.59	280	525
	M9.652.604	○	○	○	○	2.20	1.50	1.58	2.23	3.15	3.86	4.98	7.04	280	520
	M9.652.644	○	○	○	○	2.50	1.60	2.00	2.83	4.00	4.90	6.33	8.94	275	520
	M9.652.674	○	○	○	○	2.70	1.80	2.38	3.36	4.75	5.82	7.51	10.62	275	520
	M9.652.724	○	○	○	○	3.00	2.10	3.15	4.46	6.30	7.72	9.96	14.09	275	520
	M9.652.764	○	○	○	-	3.50	2.30	4.00	5.66	8.00	9.80	12.65	17.86	270	515
	M9.652.804	○	○	○	○	4.00	2.60	5.00	7.07	10.00	12.25	15.81	22.36	270	510
	M9.652.844	○	-	-	○	4.50	3.00	6.25	8.84	12.50	15.31	19.76	27.95	270	510
	M9.652.884	○	-	○	-	5.00	3.40	8.00	11.31	16.00	19.60	25.30	35.78	270	505



Rotating nozzle for precise adjustment of jet direction.  
 Long service life  
 Applications:  
 Lubricating, cooling, cleaning.

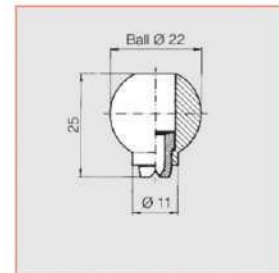

Spray angle	Ordering no.			A ∅ [mm]	E ∅ [mm]	V̇ [l/min]						Spray width B at p = 2 bar	
	Type	Material no.				p [bar] (p <sub>max</sub> = 30 bar)							
		16	30			0.5	1.0	2.0	3.0	5.0	10.0		
		303 SS	Brass									H=250 mm	H=500 mm
45°	M10.676.303	○	○	0.70	0.50	0.16*	0.23*	0.32	0.39	0.51	0.72	150	270
	M10.676.363	○	○	1.00	0.60	0.31*	0.44*	0.63	0.77	1.00	1.40	155	280
	M10.676.403	○	○	1.20	0.90	0.50*	0.71	1.00	1.23	1.58	2.24	175	320
	M10.676.483	○	○	1.50	1.10	0.80	1.13	1.60	1.96	2.53	3.58	180	340
	M10.676.563	○	○	2.00	1.40	1.25	1.77	2.50	3.06	3.95	5.59	185	355
	M10.676.643	○	○	2.50	1.80	2.00	2.83	4.00	4.90	6.33	8.94	195	370
	M10.676.723	○	○	3.00	2.40	3.15	4.46	6.30	7.72	9.96	14.09	200	375
	M10.676.763	○	○	3.50	2.60	4.00	5.66	8.00	9.80	12.65	17.89	200	380
M10.676.803	○	○	4.00	3.00	5.00	7.07	10.00	12.25	15.81	22.36	205	385	
60°	M10.676.304	○	○	0.70	0.40	0.16*	0.23*	0.32	0.39	0.51	0.72	215	425
	M10.676.334	○	○	0.90	0.50	0.22*	0.32*	0.45	0.55	0.71	1.01	220	440
	M10.676.364	○	○	1.00	0.60	0.31*	0.44*	0.63	0.77	1.00	1.40	230	460
	M10.676.404	○	○	1.20	0.80	0.50*	0.71	1.00	1.23	1.58	2.24	245	485
	M10.676.444	○	○	1.35	0.90	0.62*	0.88	1.25	1.53	1.98	2.80	255	495
	M10.676.484	○	○	1.50	1.00	0.80*	1.13	1.60	1.96	2.53	3.58	260	510
	M10.676.514	○	○	1.65	1.10	0.95*	1.34	1.90	2.33	3.00	4.25	270	520
	M10.676.564	○	○	2.00	1.30	1.25	1.77	2.50	3.06	3.95	5.59	280	535
	M10.676.604	○	○	2.20	1.50	1.58	2.23	3.15	3.86	4.98	7.04	290	550
	M10.676.644	○	○	2.50	1.60	2.00	2.83	4.00	4.90	6.33	8.94	295	565
	M10.676.674	○	○	2.70	1.80	2.38	3.36	4.75	5.82	7.51	10.62	300	575
	M10.676.724	○	○	3.00	2.10	3.15	4.46	6.30	7.72	9.96	14.09	305	590
M10.676.764	○	○	3.50	2.30	4.00	5.66	8.00	9.80	12.65	17.89	310	595	
90°	M10.676.216	○	○	0.40	0.20	-	0.08*	0.11	0.14	0.18	0.25	370	700
	M10.676.276	○	○	0.60	0.30	0.11*	0.16*	0.22	0.27	0.35	0.49	375	720
	M10.676.306	○	○	0.70	0.40	0.16*	0.23*	0.32	0.39	0.51	0.72	380	740
	M10.676.336	○	○	0.90	0.50	0.22*	0.32*	0.45	0.55	0.71	1.01	415	800
	M10.676.366	○	○	1.00	0.50	0.31*	0.44*	0.63	0.77	1.00	1.40	420	810
	M10.676.406	○	○	1.20	0.70	0.50*	0.71	1.00	1.23	1.58	2.24	430	820
	M10.676.446	○	○	1.35	0.80	0.62*	0.88	1.25	1.53	1.98	2.80	435	830
	M10.676.486	○	○	1.50	0.80	0.80*	1.13	1.60	1.96	2.53	3.58	440	835
	M10.676.516	○	○	1.65	0.90	0.95*	1.34	1.90	2.33	3.00	4.25	440	840
	M10.676.566	○	○	2.00	1.10	1.25	1.77	2.50	3.06	3.95	5.59	445	850
	M10.676.606	○	○	2.20	1.20	1.58	2.23	3.15	3.86	4.98	7.04	450	860
	M10.676.646	○	○	2.50	1.30	2.00	2.83	4.00	4.90	6.33	8.94	455	865
	M10.676.676	○	○	2.70	1.40	2.38	3.36	4.75	5.82	7.51	10.62	465	875
	M10.676.726	○	○	3.00	1.70	3.15	4.46	6.30	7.72	9.96	14.09	470	885







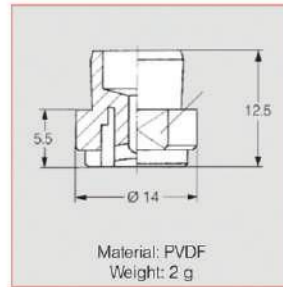

Spray angle	Ordering no.		A Ø [mm]	E Ø [mm]	ṽ [l/min]						Spray width B at p = 2 bar	
	Type	Mat. no 5E.03 PVDF			p[bar] P <sub>max</sub> =2 bar						 H=250 mm    H=500 mm	
					0.5	1.0	2.0	3.0	5.0	10.0	B	B
90°	M12.612.366	○	1.0	0.5	0.24	0.31	0.37	0.44	0.55	0.63	505	980
	M12.612.486	○	1.5	0.6	0.62	0.80	0.95	1.13	1.39	1.60	525	1020
120°	M12.612.487	○	1.5	0.6	0.62	0.80	0.95	1.13	1.39	1.60	800	1460
	M12.612.647	○	2.5	1.2	1.55	2.00	2.37	2.83	3.46	4.00	800	1460

Example            Type    +    Material no.    =    Ordering no.  
 for ordering: M12.612.366 + 5E.03            =    M12.612.366.5E.03

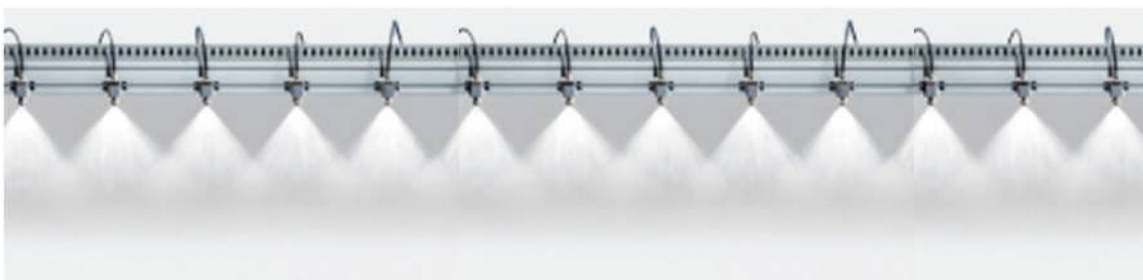
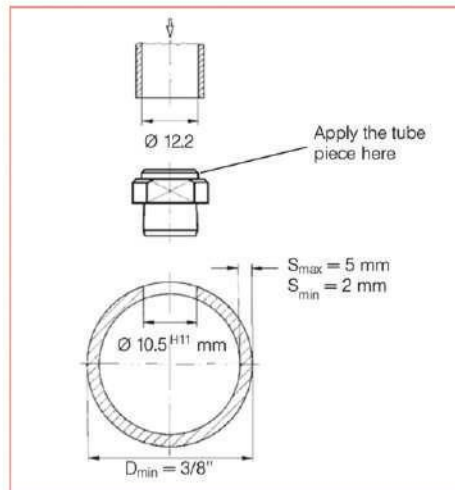

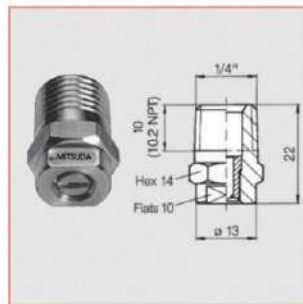
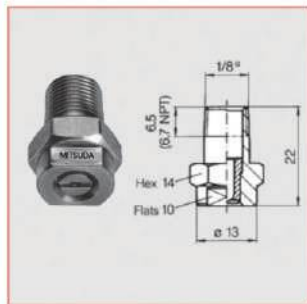

US gal/min. at 40 psi	Nozzle code			Flow rate code				A Ø [mm]	V̇ [l/min]						
	Connection			Spray angle					p [bar]						
	1/8	1/4	Nut	20°	30°	45°	60°		40	60	80	100	120	150	200
02	MH.608	MH.602	MH.652	361	362	363	364	1.00	2.88	3.53	4.08	4.56	5.00	5.58	5.00
021	MH.608	MH.602	MH.652	371	372	373	374	1.02	3.03	3.71	4.28	4.79	5.25	5.87	6.77
025	MH.608	MH.602	MH.652	381	382	383	384	1.10	3.60	4.42	5.10	5.70	6.24	6.98	8.06
028	MH.608	MH.602	MH.652	391	392	393	394	1.16	4.04	4.94	5.71	6.38	6.99	7.81	9.02
03	MH.608	MH.602	MH.652	401	402	403	404	1.18	4.32	5.29	6.11	6.83	7.48	8.37	9.66
034	MH.608	MH.602	MH.652	411	412	413	414	1.30	4.90	6.00	6.93	7.75	8.49	9.49	10.96
038	MH.608	MH.602	MH.652	441	442	443	-	1.33	5.48	6.72	7.75	8.67	9.50	10.62	12.26
04	MH.608	MH.602	MH.652	451	452	453	454	1.35	5.77	7.06	8.16	9.12	9.99	11.17	12.90
043	MH.608	MH.602	MH.652	461	462	-	-	1.38	6.20	7.59	8.77	9.80	10.74	12.00	13.86
045	MH.608	MH.602	MH.652	471	472	473	474	1.40	6.49	7.95	9.18	10.26	11.24	12.57	14.51
05	MH.608	MH.602	MH.652	481	482	483	484	1.55	7.21	8.83	10.20	11.40	12.49	13.96	16.12
055	MH.608	MH.602	MH.652	501	502	503	504	1.60	7.93	9.71	11.22	12.54	13.74	15.36	17.73
06	MH.608	MH.602	MH.652	521	522	523	524	1.72	8.85	10.60	12.24	13.68	14.99	16.75	19.35
065	MH.608	MH.602	MH.652	531	532	533	534	1.75	9.37	11.48	13.26	14.82	16.23	18.15	20.96
07	MH.608	MH.602	MH.652	541	542	543	544	1.80	10.09	12.36	14.28	15.96	17.48	19.55	22.57
075	MH.608	MH.602	MH.652	551	552	553	554	1.90	10.81	13.25	15.29	17.10	18.73	20.94	24.18
08	MH.608	MH.602	MH.652	571	572	573	574	2.05	11.54	14.13	16.31	18.24	19.98	22.34	25.80
087	MH.608	MH.602	MH.652	581	582	583	584	2.06	12.54	15.36	17.74	19.83	21.72	24.29	28.04
09	MH.608	MH.602	MH.652	591	592	593	594	2.10	12.98	15.89	18.35	20.52	22.48	25.13	29.02
10	MH.608	MH.602	MH.652	601	602	603	604	2.30	14.41	17.65	20.38	22.79	24.97	27.91	32.23
11	-	MH.602	MH.652	621	622	623	624	2.40	15.86	19.42	22.42	25.07	27.46	30.70	35.45
125	-	MH.602	MH.652	641	642	643	644	2.50	18.02	22.07	25.48	28.49	31.21	34.89	40.29
131	-	MH.602	MH.652	651	652	653	654	2.55	18.89	23.13	26.71	29.86	32.71	36.57	42.23
139	-	MH.602	MH.652	661	662	663	664	2.65	20.04	24.54	28.34	31.68	34.70	38.80	44.80
15	-	MH.602	MH.652	671	672	673	674	2.70	21.62	26.48	30.58	34.19	37.45	41.87	48.35
175	-	MH.602	MH.652	701	702	703	704	3.00	25.53	30.90	35.68	39.89	43.70	48.86	56.41
20	-	MH.602	MH.652	-	-	723	724	3.05	28.83	35.31	40.78	45.59	49.94	55.84	64.47
25	-	MH.602	MH.652	-	-	763	764	3.50	36.04	44.14	50.97	56.99	62.43	69.80	80.60
30	-	MH.602	MH.652	-	-	793	-	3.90	43.25	52.97	61.16	68.38	74.91	83.75	96.70

Connection code	Connection	p <sub>max</sub> * [bar]
A3.00	BSPT	approx.700
A3.07	NPT	approx.700
A3.29	Retaining nut	approx.300

**Example for ordering:** Nozzle code **MH.602** + Flow rate code **+ 361** + Connection code **+ A3.07** = Ordering no. **= MH.608.361.A3.07**  
 (Flat fan 20°; 4.52 l/min.at 100 bar; 1/4 NPT)

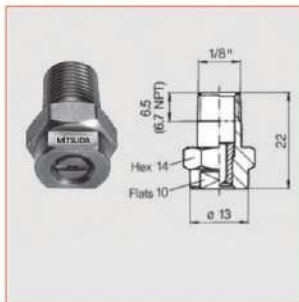

US gal/min. at 40 psi	Nozzle code	Flow rate code				Mat no	A Ø [mm]	V̇ [l/min]						
		Spray angle						p [bar]						
		20°	30°	45°	60°			40	60	80	100	120	150	200
02	MFH.6FH	361	362	363	364	○	1.00	2.88	3.53	4.08	4.56	5.00	5.58	6.45
021	MFH.6FH	371	372	373	374	○	1.02	3.03	3.71	4.28	4.79	5.25	5.87	6.77
025	MFH.6FH	381	382	383	384	○	1.10	3.60	4.42	5.10	5.70	6.24	6.98	8.06
028	MFH.6FH	391	392	393	394	○	1.16	4.04	4.94	5.71	6.38	6.99	7.81	9.02
03	MFH.6FH	401	402	403	404	○	1.18	4.32	5.29	6.11	6.83	7.48	8.37	9.66
034	MFH.6FH	411	412	413	414	○	1.30	4.90	6.00	6.93	7.75	8.49	9.49	10.96
038	MFH.6FH	441	442	443	444	○	1.33	5.48	6.72	7.75	8.67	9.50	10.62	12.26
04	MFH.6FH	451	452	453	454	○	1.35	5.77	7.06	8.16	9.12	9.99	11.17	12.90
043	MFH.6FH	461	462	-	-	○	1.38	6.20	7.59	8.77	9.80	10.74	12.00	13.86
045	MFH.6FH	471	472	473	474	○	1.40	6.49	7.95	9.18	10.26	11.24	12.57	14.51
05	MFH.6FH	481	482	483	484	○	1.55	7.21	8.83	10.20	11.40	12.49	13.96	16.12
055	MFH.6FH	501	502	503	504	○	1.60	7.93	9.71	11.22	12.54	13.74	15.36	17.73
06	MFH.6FH	521	522	523	524	○	1.72	8.85	10.60	12.24	13.68	14.99	16.75	19.35
065	MFH.6FH	531	532	533	534	○	1.75	9.37	11.48	13.26	14.82	16.23	18.15	20.96
07	MFH.6FH	541	542	543	543	○	1.80	10.09	12.36	14.28	15.96	17.48	19.55	22.57
075	MFH.6FH	551	552	553	554	○	1.90	10.81	13.25	15.29	17.10	18.73	20.94	24.18
08	MFH.6FH	571	572	573	574	○	2.05	11.54	14.13	16.31	18.24	19.98	22.34	25.80
087	MFH.6FH	581	582	583	584	○	2.06	12.54	15.36	17.74	19.83	21.72	24.29	28.04
09	MFH.6FH	591	592	593	594	○	2.10	12.98	15.89	18.35	20.52	22.48	25.13	29.02
10	MFH.6FH	601	602	603	604	○	2.30	14.41	17.65	20.38	22.79	24.97	27.91	32.23
11	MFH.6FH	621*	622*	623*	624*	○	2.40	15.86	19.42	22.42	25.07	27.46	30.70	35.45
125	MFH.6FH	641*	642*	643*	644*	○	2.50	18.02	22.07	25.48	28.49	31.21	34.89	40.29
131	MFH.6FH	651*	652*	653*	654*	○	2.55	18.89	23.13	26.71	29.86	32.71	36.57	42.23
139	MFH.6FH	661*	662*	663*	664*	○	2.65	20.04	24.54	28.34	31.68	34.70	38.80	44.80
15	MFH.6FH	671*	672*	673*	674*	○	2.70	21.62	26.48	30.58	34.19	37.45	41.87	48.35
175	MFH.6FH	701*	702*	703*	704*	○	3.00	25.53	30.90	35.68	39.89	43.70	48.86	56.41
20	MFH.6FH	-	-	723*	724*	○	3.05	28.83	35.31	40.78	45.59	49.94	55.84	64.47
25	MFH.6FH	-	-	763*	764*	○	3.50	36.04	44.14	50.97	56.99	62.43	69.80	80.60
30	MFH.6FH	-	-	793*	-	○	3.90	43.25	52.97	61.16	68.38	74.91	83.75	96.70

Connection code	Connection	P <sub>max</sub> [bar]
CA	1/8 BSPT	approx.700
BA	1/8 NPT	approx.700
CC	1/4 BSPT	approx.700
BC	1/4 NPT	approx.700
29	Retaining nut	approx.300

**Example for ordering:** Nozzle code MFH.6FH + Flow rate code 361 + Material no. A3 + Connection code CA = Ordering no. MFH.6FH.361.A3.CA = (Flat fan 20 , 4.56 l/min. at 100 bar; 1/8 BSPT)

Wide flat fan with a sharply surrounded spray pattern.  
Non clogging design.  
Applications: Cleaning and washing applications requiring strong water jet, foam control in drain treatment facilities and storage tanks.

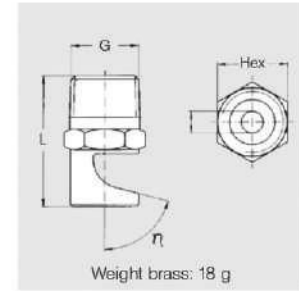

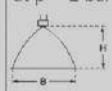
Spray angle	η	Ordering no.							B ∅ [mm]	ṽ [l/min]			Dimensions								Spray width B at p = 2 bar  H=250 mm	
		Type	Material no.			Code G				p [bar]			L [mm]				Hex [mm]					
			16 303 SS	30 Brass	5E PVDF	1/8 BSPT	1/4 BSPT	3/8 BSPT		1/2 BSPT	1.0	2.0	5.0	R 1/8	R 1/4	R 3/8	R 1/2	R 1/8	R 1/4	R 3/8		R 1/2
90°	75°	M3.686.366	-	○	-	CA	-	-	-	0.80	0.45	0.63	1.00	22	-	-	-	11	-	-	-	520
	75°	M3.686.406	○	○	-	CA	-	-	-	1.00	0.71	1.00	1.58	23	-	-	-	11	-	-	-	525
	40°	M3.686.686	○	○	-	-	CC	-	-	2.40	3.54	5.00	7.91	-	29	-	-	-	14	-	-	530
	40°	M3.686.726	-	○	-	CA	-	-	-	2.70	4.45	6.30	9.96	26	-	-	-	11	-	-	-	530
	40°	M3.686.806	○	○	-	-	CC	-	-	3.40	7.07	10.00	15.81	-	34	-	-	-	14	-	-	530
	40°	M3.686.886	○	-	-	-	CC	-	-	4.20	11.31	16.00	25.30	-	36	-	-	-	17	-	-	530
	40°	M3.686.926	○	-	-	-	-	CE	-	4.70	14.14	20.00	31.62	-	-	39	-	-	-	17	-	530
120°	75°	M3.686.368	○	○	-	CA	-	-	-	0.80	0.45	0.63	1.00	23	-	-	-	11	14	-	-	1360
		M3.686.408	○	○	-	CA	-	-	-	1.00	0.71	1.00	1.58	23	-	-	-	11	14	-	-	1370
		M3.686.448	○	○	-	-	CC	-	-	1.20	0.88	1.25	1.98	-	28	-	-	-	14	-	-	1370
		M3.686.488	○	○	-	CA	CC	-	-	1.30	1.13	1.60	2.53	23	28	-	-	11	14	-	-	1370
		M3.686.528	○	○	-	CA	CC	-	-	1.50	1.41	2.00	3.16	23	28	-	-	11	14	-	-	1370
		M3.686.568	○	○	○*	CA	CC	-	-	1.70	1.77	2.50	3.59	23	28	-	-	11	14	-	-	1370
		M3.686.608	○	○	-	CA	CC	CE	-	1.90	2.23	3.15	4.98	23	28	-	-	11	14	-	-	1370
		M3.686.648	○	○	-	-	CC	-	-	2.20	2.83	4.00	6.32	-	28	-	-	-	14	-	-	1370
		M3.686.688	○	○	-	CA	CC	-	-	2.40	3.54	5.00	7.91	23	28	-	-	11	14	-	-	1370
		M3.686.728	○	○	-	CA	CC	-	-	2.70	4.45	6.30	9.96	23	28	-	-	11	14	-	-	1370
		M3.686.768	○	○	-	-	CC	-	-	3.00	5.66	8.00	12.65	-	28	-	-	-	14	-	-	1370
		M3.686.808	○	○	-	CA	CC	-	-	3.40	7.07	10.00	15.81	23	28	-	-	11	14	-	-	1370
		M3.686.828	○	○	-	-	CC	CE	-	3.60	7.92	11.20	17.71	-	28	-	-	-	14	-	-	1370
		M3.686.848	○	○	-	-	CC	-	-	3.80	8.80	12.50	19.76	-	28	-	-	-	14	-	-	1370
		M3.686.868	○	○	-	-	CC	-	-	4.00	9.90	14.00	22.14	-	28	-	-	-	14	-	-	1370
		M3.686.888	○	○	-	-	CC	-	-	4.20	11.31	16.00	25.30	-	28	-	-	-	14	-	-	1370
		M3.686.908	○	○	-	-	CC	-	-	4.50	12.73	18.00	28.46	-	28	-	-	-	14	-	-	1370
		M3.686.928	○	-	-	-	-	CE	-	4.70	14.14	20.00	31.62	-	-	32	-	-	-	17	-	1370
		M3.686.968	-	○	-	-	-	-	CG	5.30	17.68	25.00	39.53	-	-	32	40	-	-	17	22	1370
		M3.686.988	○	-	-	-	-	CE	CG	5.60	19.80	28.00	44.27	-	-	32	40	-	-	17	22	1370

Example for ordering: Type M3.686.366 + Material no. 30 + Code CA = Ordering no. M3.686.366.30.CA



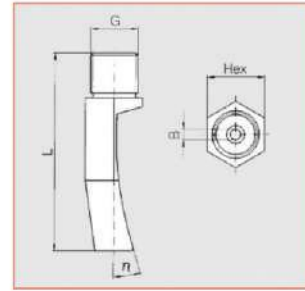

Spray angle $\Delta$	$\eta$	Ordering no.						B $\varnothing$ [mm]	$\dot{V}$ [l/min]				Dimensions		Weight	Spray width B at p = 2 bar		
		Type	Material no.			Code G			p [bar]				L [mm]	Hex [mm]				
			16	30	5E	1/4 BSPT	3/8 BSPT		3/4 BSPT	0.5	1.0	2.0				5.0	H = 250 [mm]	H = 500 [mm]
		303 SS	Brass	PVDF														
45°	36°	MK12.688.603	○	-	-	CC	-	-	1.9	1.57	2.23	3.15	4.98	31	114	50	220	440
	36°	MK12.688.723	○	-	-	CE	-	-	2.7	3.15	4.45	6.30	9.96	44	17	107	220	440
	35°	MK12.688.763	○	-	-	CE	-	-	3.0	4.00	5.66	8.00	12.65	43	19	120	220	440
	30°	MK12.688.843	○	○	-	CE	-	-	3.8	6.25	8.84	12.50	19.76	50	19	140	220	440
	27°	MK12.688.883	○	-	-	CE	-	-	4.3	8.00	11.31	16.00	25.30	67	22	240	220	440
	29°	MK12.688.923	○	○	-	CE	-	-	4.8	10.00	14.14	20.00	31.62	59	22	260	220	440
	29°	MK12.688.943	○	-	-	CE	-	-	4.9	11.20	15.84	22.40	35.41	62	22	300	220	440
	29°	MK12.688.963	○	-	-	CE	-	-	5.4	12.50	17.68	25.00	39.53	74	22	432	220	440
	35°	MK13.689.003	○	-	○	-	-	90	6.0	15.75	22.27	31.50	49.81	80	32/24	306/33	250	490
	21°	MK13.689.043	○	○	-	CE	-	-	6.9	20.00	28.28	40.00	63.25	67	24	630	250	490
	18°	MK13.689.083	○	○	-	CE	-	-	7.6	25.00	35.36	50.00	79.06	74	24	625	250	490
	18°	MK13.689.123	○	○	-	CE	-	-	8.6	31.50	44.55	63.00	99.61	79	24	610	250	490

**Example**      Type      + Material no.      + Code = Ordering no.  
**for ordering:** MK12.688.603 + 16                      + CC = MK12.688.603.16.CC



Spray angle	Ordering no.									B ∅ [mm]	E ∅ [mm]	V̇ [l/min]							Spray diameter D at p=2 bar	
	Type	Mat. no.		Code								p [bar]							H=200 mm	H=500 mm
		1Y	30	1/8 BSPT	1/4 BSPT	3/8 BSPT	1/2 BSPT	3/4 BSPP	1 BSPP			0.5	1.0	2.0	3.0	5.0	7.0	10.0		
		316L SS	Brass																	
45°	M4.490.403	○	○	CA	-	-	-	-	-	1.25	1.25	0.57	0.76	1.00	1.18	1.44	1.65	1.90	160	400
	M4.490.523	○	○	CA	-	-	-	-	-	1.70	1.70	1.15	1.52	2.00	2.35	2.89	3.30	3.81	160	400
	M4.490.603	○	○	-	CC	CE	-	-	-	2.00	2.00	1.81	2.39	3.15	3.70	4.54	5.20	6.00	160	400
	M4.490.643	○	○	-	CC	CE*	-	-	-	2.45	2.45	2.30	3.03	4.00	4.70	5.77	6.60	7.61	160	400
	M4.490.683	-	○	-	-	CE*	-	-	-	2.55	2.55	2.87	3.79	5.00	5.88	7.21	8.25	9.52	160	400
	M4.490.703	-	○	-	-	CE	-	-	-	2.65	2.65	3.22	4.24	5.60	6.59	8.08	9.24	10.66	160	400
	M4.490.723	○	○	-	-	CE	-	-	-	2.85	2.85	3.62	4.77	6.30	7.41	9.09	10.40	11.99	160	400
	M4.490.783	-	○	-	-	-	CG	-	-	3.45	3.45	5.17	6.82	9.00	10.58	12.98	14.85	17.12	160	400
	M4.490.843	-	○	-	-	-	CG	-	-	3.80	3.80	7.18	9.47	12.50	14.70	18.03	20.63	23.80	160	400
60°	M4.490.404	○	○	CA	-	-	-	-	-	1.15	1.15	0.57	0.76	1.00	1.18	1.44	1.65	1.90	220	560
	M4.490.444	○	-	CA	-	-	-	-	-	1.25	1.25	0.72	0.95	1.25	1.47	1.80	2.06	2.38	220	560
	M4.490.484	○	○	CA	-	-	-	-	-	1.45	1.45	0.92	1.21	1.60	1.88	2.31	2.64	3.05	220	560
	M4.490.524	○	○	CA	-	-	-	-	-	1.60	1.60	1.15	1.52	2.00	2.35	2.89	3.30	3.81	220	560
	M4.490.564	○	○	CA	-	-	-	-	-	1.80	1.80	1.44	1.89	2.50	2.94	3.61	4.13	4.76	220	560
	M4.490.604	○	○	CA	CC	CE*	-	-	-	2.05	2.05	1.81	2.39	3.15	3.70	4.54	5.20	6.00	220	560
	M4.490.644	○	○	-	CC	CE	-	-	-	2.30	2.30	2.30	3.03	4.00	4.70	5.77	6.60	7.61	220	560
	M4.490.684	○	○	-	CC	CE	-	-	-	2.60	2.60	2.87	3.79	5.00	5.88	7.21	8.25	9.52	220	560
	M4.490.724	○	○	-	CC	CE	-	-	-	2.95	2.80	3.62	4.77	6.30	7.41	9.09	10.40	11.99	220	560
	M4.490.764	○	○	-	-	CE	-	-	-	3.25	3.25	4.59	6.06	8.00	9.41	11.54	13.20	15.22	220	560
	M4.490.804	○	○	-	-	CE	-	-	-	3.70	3.70	5.74	7.58	10.00	11.76	14.43	16.51	19.02	220	560
	M4.490.844	○	○	-	-	-	CG	-	-	4.05	4.05	7.18	9.47	12.50	14.70	18.03	20.63	28.80	220	560
	M4.490.884	○	○	-	-	-	CG	-	-	4.65	4.65	9.19	12.13	16.00	18.82	28.03	26.41	30.46	220	560
	M4.490.924	○	○	-	-	-	-	AK	-	5.20	5.20	11.49	15.16	20.00	23.52	28.85	33.01	38.07	220	560
	M4.490.964	○	○	-	-	-	-	AK	-	5.80	5.80	14.39	18.95	25.00	29.40	36.07	41.26	47.59	220	560
	M4.491.044	○	○	-	-	-	-	-	AM	7.25	7.25	22.97	30.31	40.00	47.04	57.71	66.02	76.15	220	560
	M4.491.084	○	○	-	-	-	-	-	AM	8.15	8.15	28.72	37.89	50.00	58.80	72.14	82.53	95.18	220	560

This series provides a non-clogging nozzle design.  
 Stable spray angel, exceptionally even liquid distribution, and large free cross sections.  
 Applications: Cleaning and washing applications, container cleaning, degassing, container cleaning.



**Series M4.490/491 takes part within the axial-flow full cone nozzles. These nozzle series are used instead of M4.460/461 that still available on request.**

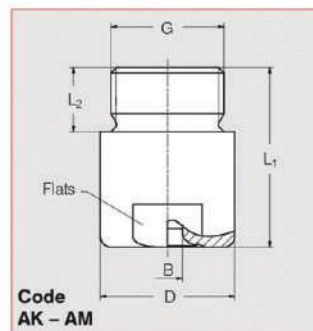
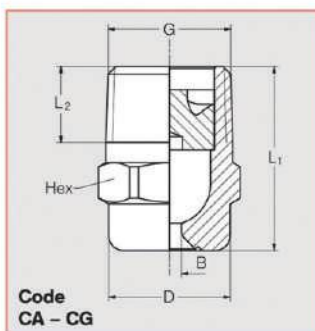

Code	Dimensions [mm]				Hex/Flats	Weight brass
	G	L <sub>1</sub>	L <sub>2</sub>	D		
CA	1/8 BSPT	18.0	6.5	10.0	11	13 g
CC	1/4 BSPT	22.0	10.0	13.0	14	16 g
CE	3/8 BSPT	24.5	10.0	16.0	17	30 g
CE	3/8 BSPT	30.0	10.0	16.0	17	50 g
CG	1/2 BSPT	32.5	13.0	21.0	22	60 g
CG	1/2 BSPT	43.5	13.0	21.0	22	85 g
AK	3/4 BSPP	42.0	15.0	32.0	27	190 g
AM	1 BSPP	56.0	17.0	40.0	36	350 g

Spray angle	Ordering no.									B Ø [mm]	E Ø [mm]	V̇ [l/min]							Spray diameter D at p=2 bar	
	Type	Mat. no.		Code								p [bar]								
		1Y	30	1/8 BSPT	1/4 BSPT	3/8 BSPT	1/2 BSPT	3/4 BSPP	1 BSPP			0.5	1.0	2.0	3.0	5.0	7.0	10.0	H=200 mm	H=500 mm
		316L SS	Brass																	
90°	M4.490.406	○	○	CA	-	-	-	-	-	1.20	1.20	0.57	0.76	1.00	1.18	1.44	1.65	1.90	380	400
	M4.490.446	-	○	CA	-	-	-	-	-	1.30	1.30	0.72	0.95	1.25	1.47	1.80	2.06	2.38	160	400
	M4.490.486	○	○	CA	-	-	-	-	-	1.45	1.45	0.92	1.21	1.60	1.88	2.31	2.64	3.05	160	400
	M4.490.526	○	○	CA	-	-	-	-	-	1.70	1.55	1.15	1.52	2.00	2.35	2.89	3.30	3.81	160	400
	M4.490.566	○	○	CA	-	-	-	-	-	1.90	1.90	1.44	1.89	2.50	2.94	3.61	4.13	4.76	160	400
	M4.490.606	○	○	CA	-	CE	-	-	-	2.10	2.05	1.81	2.39	3.15	3.70	4.54	5.20	6.00	160	400
	M4.490.646	○	○	-	CC	CE	-	-	-	2.40	2.40	2.30	3.03	4.00	4.70	5.77	6.60	7.61	160	400
	M4.490.686	○	○	-	CC	CE	CG	-	-	2.70	2.70	2.87	3.79	5.00	5.88	7.21	8.25	9.52	160	400
	M4.490.726	○	○	-	CC	CE	CG	-	-	3.20	2.80	3.62	4.77	6.30	7.41	9.09	10.40	11.99	160	400
	M4.490.746	○	○	-	-	CE	-	-	-	3.15	3.15	4.08	5.38	7.10	8.35	10.24	11.72	13.52	160	400
	M4.490.766	○	○	-	-	CE	-	-	-	3.40	3.40	4.59	6.06	8.00	9.41	11.54	13.20	15.22	160	400
	M4.490.806	○	○	-	-	CE	-	-	-	3.90	3.90	5.74	7.58	10.00	11.76	14.43	16.51	19.04	160	400
	M4.490.846	○	○	-	-	CE	-	-	-	4.65	4.00	7.18	9.47	12.50	14.70	18.03	20.63	23.80	160	400
	M4.490.886	○	○	-	-	-	CG	-	-	5.45	4.50	9.19	12.13	16.00	18.82	23.08	26.41	30.46	160	400
	M4.490.926	○	○	-	-	-	CG	-	-	5.90	4.50	11.49	15.16	20.00	23.52	28.85	33.01	38.07	160	400
	M4.490.966	○	○	-	-	-	CG	AK	-	6.55	4.85	14.36	18.95	25.00	29.40	36.07	41.26	47.59	160	400
	M4.491.006	○	○	-	-	-	-	AK	-	7.55	5.50	18.09	23.87	31.50	37.05	45.45	51.99	59.97	160	400
	M4.491.046	○	○	-	-	-	-	AK	-	8.60	6.60	22.97	30.31	40.00	47.04	57.71	66.02	76.15	160	400
	M4.491.086	○	○	-	-	-	-	-	AK	9.45	7.25	28.72	37.89	50.00	58.80	72.14	82.53	95.18	160	400
M4.491.126	○	○	-	-	-	-	-	AK	10.40	8.00	36.18	47.75	63.00	74.09	90.89	103.98	119.93	160	400	
M4.491.146	○	-	-	-	-	-	-	AK	11.00	7.50	40.78	53.81	71.00	83.50	102.43	117.19	135.16	160	400	
120°	M4.490.368	○	○	CA	-	-	-	-	-	0.85	0.65	0.36	0.48	0.63	0.74	0.91	1.04	1.20	680	1220
	M4.490.408	○	○	CA	-	-	-	-	-	1.20	1.20	0.57	0.76	1.00	1.18	1.44	1.65	1.90	680	1220
	M4.490.448	○	○	CA	-	-	-	-	-	1.30	1.30	0.72	0.95	1.25	1.47	1.80	2.06	2.38	680	1220
	M4.490.488	○	○	CA	-	-	-	-	-	1.45	1.45	0.92	1.21	1.60	1.88	2.31	2.64	3.05	680	1220
	M4.490.528	○	○	CA	-	-	-	-	-	1.70	1.70	1.15	1.52	2.00	2.35	2.89	3.30	3.81	680	1220
	M4.490.568	○	○	CA	-	CE	-	-	-	1.90	1.90	1.44	1.89	2.50	2.94	3.61	4.13	4.76	680	1220
	M4.490.608	○	○	-	CC	CE	-	-	-	2.10	2.05	1.81	2.39	3.15	3.70	4.54	5.20	6.00	680	1330
	M4.490.648	○	○	-	CC	CE	CG	-	-	2.40	2.40	2.30	3.03	4.00	4.70	5.77	6.60	7.61	680	1330
	M4.490.688	○	○	-	CC	CE	CG	-	-	2.75	2.75	2.87	3.79	5.00	5.88	7.21	8.25	9.52	680	1330
	M4.490.728	○	○	-	-	CE	-	-	-	3.20	2.80	3.62	4.77	6.30	7.41	9.09	10.40	11.99	680	1330
	M4.490.748	○	○	-	-	CE	-	-	-	3.20	3.20	4.08	5.38	7.10	8.35	10.24	11.72	13.52	680	1330
	M4.490.768	○	○	-	-	CE	-	-	-	3.45	3.45	4.59	6.44	8.00	9.41	11.54	13.20	15.22	680	1330
	M4.490.808	○	○	-	-	CE	-	-	-	3.90	3.90	5.74	7.58	10.00	11.76	14.43	16.51	19.04	680	1330
	M4.490.848	○	○	-	-	-	CG	-	-	4.70	4.00	7.18	9.47	12.50	14.70	18.03	20.63	23.80	680	1330
	M4.490.888	○	○	-	-	-	CG	-	-	5.10	4.50	9.19	12.13	16.00	18.82	23.08	26.41	30.46	680	1330
	M4.490.928	○	○	-	-	-	CG	-	-	5.80	4.75	11.49	15.16	20.00	23.52	28.85	33.01	38.07	680	1330
	M4.490.968	○	○	-	-	-	-	AK	-	6.65	4.85	14.36	18.95	25.00	29.40	36.07	41.26	47.59	680	1330
	M4.491.048	○	○	-	-	-	-	AK	-	9.20	5.85	22.97	30.31	40.00	47.04	57.71	66.02	76.15	680	1330
	M4.491.128	○	○	-	-	-	-	-	AM	10.80	7.75	36.18	47.75	63.00	74.09	90.89	103.98	119.93	680	1330
M4.491.148	○	-	-	-	-	-	-	AM	11.40	7.65	40.78	53.81	71.00	83.50	102.43	117.19	135.16	680	1330	

Example      Type      +      Material no.      +      Code      =      Ordering no.  
 for ordering: M4.490.406 + 1Y                      + CA      = M4.490.406.1Y.CA

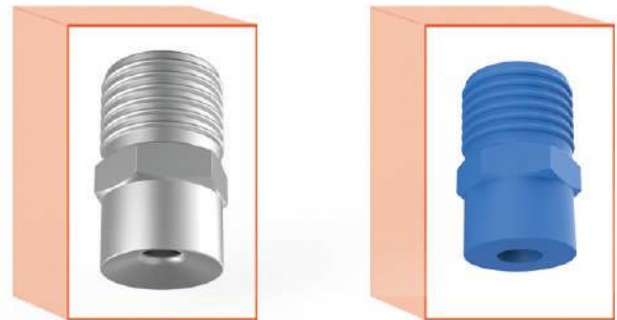
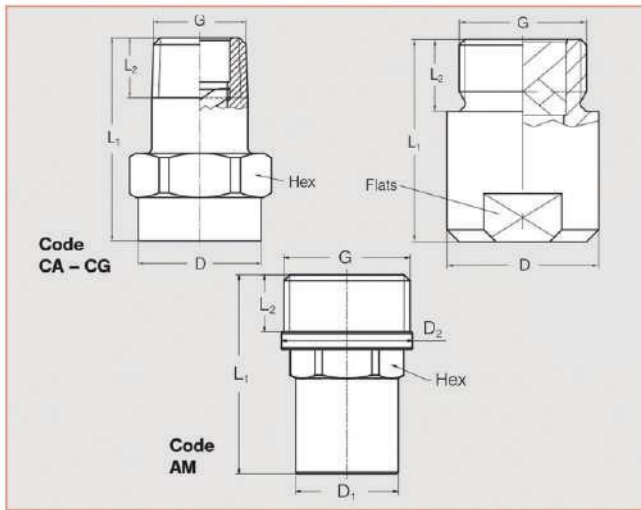

Code	Dimensions [mm]					Hex/ Flats
	G	L <sub>1</sub>	L <sub>2</sub>	D <sub>1</sub>	D <sub>2</sub>	
<b>CA</b>	1/8 BSPT	22.0	6.5	13.0	-	14
<b>CC</b>	1/4 BSPT	22.0	9.7	13.0	-	14
<b>CE</b>	3/8 BSPT	30.0	10.0	17.0	-	17
<b>CG</b>	1/2 BSPT	43.5	13.2	22.0	-	22
<b>AK</b>	3/4 BSPP	42.0	15.0	31.5	-	27
<b>AM</b>	1 BSPP	52.5	15.0	27.0	34.5	27

Spray angle	Ordering no.								B ∅ [mm]	E ∅ [mm]	ṽ [l/min]							Spray diameter D at p=2 bar	
	Type	Mat. no. 5E	Code					p [bar]											
			PVDF	1/8 BSPT	1/4 BSPT	3/8 BSPT	1/2 BSPT	3/4 BSPP			1 BSPP	0.5	1.0	2.0	3.0	5.0	7.0	10.0	H=200mm
60°	M46.460.524	○	CA	-	-	-	-	-	1.60	1.60	1.00	1.41	2.00	2.45	2.83	3.16	4.47	220	560
	M46.460.644	○	-	CC	-	-	-	-	2.40	1.90	2.30	3.03	4.00	4.70	5.77	6.60	7.61	220	560
	M46.460.724	○	-	CC	-	-	-	-	2.80	2.10	3.15	4.45	6.30	7.72	8.91	9.96	14.09	220	560
	M46.460.964	○	-	-	-	-	AK	-	5.80	4.90	14.36	18.95	25.00	29.40	36.07	41.26	47.59	220	560
90°	M46.460.326	○	CA	-	-	-	-	-	0.80	0.55	0.23	0.30	0.40	0.47	0.58	0.66	0.76	380	860
	M46.460.406	○	CA	-	-	-	-	-	1.20	0.85	0.57	0.76	1.00	1.18	1.44	1.65	1.90	380	860
	M46.460.486	○	CA	-	-	-	-	-	1.45	1.20	0.92	1.21	1.60	1.88	2.31	2.64	3.05	380	860
	M46.460.526	○	CA	-	-	-	-	-	1.65	1.30	1.15	1.52	2.00	2.35	2.89	3.30	3.81	380	860
	M46.460.606	○	CA	-	CE	-	-	-	2.05	1.45	1.81	2.39	3.15	3.70	4.54	5.20	6.00	380	860
	M46.460.646	○	-	CC	-	-	-	-	2.30	1.80	2.30	3.03	4.00	4.70	5.77	6.60	7.61	390	960
	M46.460.726	○	-	-	CE	-	-	-	2.95	2.00	3.62	4.77	6.30	7.41	9.09	10.40	11.99	390	960
	M46.460.746	○	-	-	CE	-	-	-	3.30	1.90	4.08	5.38	7.10	8.35	10.24	11.72	13.52	390	960
	M46.460.766	○	-	-	CE	-	-	-	3.30	2.40	4.59	6.06	8.00	9.41	11.54	13.20	15.22	390	960
	M46.460.806	○	-	-	CE	-	-	-	3.70	2.70	5.74	7.58	10.00	11.76	14.43	16.51	19.04	390	960
	M46.460.846	○	-	-	CE	-	-	-	4.05	3.20	7.18	9.47	12.50	14.70	18.03	20.63	23.80	390	960
	M46.460.886	○	-	-	CE	CG	-	-	4.70	3.10	9.19	12.13	16.00	18.82	23.08	26.41	30.46	390	960
	M46.460.926	○	-	-	-	CG	-	-	5.10	2.80	10.00	14.14	20.00	24.49	28.28	31.62	44.72	390	960
	M46.460.956	○	-	-	-	CG	-	-	5.10	2.80	10.00	14.14	20.00	24.49	28.28	31.62	44.72	390	960
	M46.460.966	○	-	-	-	CG	-	-	5.80	3.80	14.36	18.95	25.00	29.40	36.07	41.26	47.59	390	960
	M46.461.006	○	-	-	-	CG	-	-	6.40	3.80	18.09	23.87	31.50	37.05	45.45	51.99	59.97	390	960
	M46.461.046	○	-	-	-	-	CK*	-	7.20	5.30	22.97	30.31	40.00	47.04	57.71	66.02	76.15	390	960
	M46.461.068	○	-	-	-	-	AM	-	8.40	5.00	25.00	35.36	50.00	61.24	70.71	79.06	111.80	390	960

Example      Type      + Material no.      + Code = Ordering no.  
for ordering: M46.460.644 + 5E                      + CC = M46.460.644.5E.CC



Spray angle △	Ordering no.								B ∅ [mm]	E ∅ [mm]	V̇ [l/min]							Spray diameter D at p=2 bar	
	Type	Mat. no. 5E	Code					p [bar]							△				
			PVDF	1/8 BSPT	1/4 BSPT	3/8 BSPT	1/2 BSPT	3/4 BSPP			1 BSPP	0.5	1.0	2.0	3.0	5.0	7.0	10.0	H=200 mm
120°	M46.460.368	○	CA	-	-	-	-	-	0.95	0.45	0.32	0.45	0.63	0.77	0.89	1.00	1.41	680	1220
	M46.460.408	○	CA	-	-	-	-	-	1.20	0.85	0.57	0.76	1.00	1.18	1.44	1.65	1.90	680	1220
	M46.460.488	○	CA	-	-	-	-	-	1.50	1.00	0.92	1.21	1.60	1.88	2.31	2.64	3.05	680	1220
	M46.460.528	○	CA	-	-	-	-	-	1.65	1.20	1.15	1.52	2.00	2.35	2.89	3.20	3.81	680	1220
	M46.460.608	○	CA	-	-	-	-	-	2.10	1.40	1.81	2.39	3.15	3.70	4.54	5.20	6.00	680	1220
	M46.460.648	○	-	CC	-	-	-	-	2.45	1.60	2.30	3.03	4.00	4.70	5.77	6.60	7.61	680	1330
	M46.460.728	○	-	-	CE	-	-	-	3.10	1.90	3.62	4.77	6.30	7.41	9.09	10.40	11.99	680	1330
	M46.460.748	○	-	-	CE	-	-	-	3.30	1.90	4.08	5.38	7.10	8.35	10.24	11.72	13.52	680	1330
	M46.460.768	○	-	-	CE	-	-	-	3.50	1.90	4.59	6.44	8.00	9.41	11.54	13.20	15.22	680	1330
	M46.460.808	○	-	-	CE	-	-	-	3.80	2.40	5.74	7.58	10.00	11.76	14.43	16.51	19.04	680	1330
	M46.460.848	○	-	-	CE	-	-	-	4.20	2.70	7.18	9.47	12.50	14.70	18.03	20.63	23.80	680	1330
	M46.460.888	○	-	-	-	CG	-	-	4.60	3.10	9.94	12.13	16.00	18.82	23.08	26.41	30.46	680	1330
	M46.460.968	○	-	-	-	CG	-	-	5.90	4.10	14.36	18.95	25.00	29.40	36.07	41.26	47.59	680	1330
	M46.461.048	○	-	-	-	-	CK*	-	7.60	4.90	22.97	30.31	40.00	47.04	57.71	66.02	76.15	680	1330

Example      Type      +      Material no.      +      Code      =      Ordering no.  
 for ordering: M46.460.408 + 5E                      + CA      = M46.460.408.5E.CA

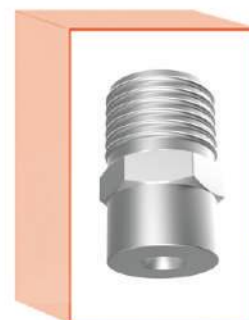
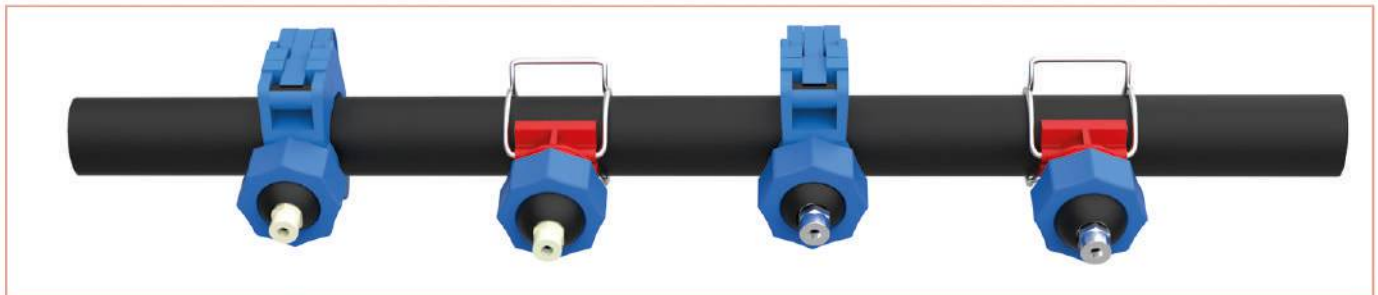

US gal/min. at 40 psi	Nozzle code			Flow rate code	B Ø [mm]	V̇ [l/min]							
	Connection		Retaining nut			p [bar]							
	1/8	1/4				40	60	80	100	120	150	200	300
01	MS.550	MS.546	MS.548	MS.300	0.60	1.44	1.77	2.04	2.28	2.50	2.79	3.22	3.95
02	MS.550	MS.546	MS.548	MS.360	0.84	2.88	3.53	4.08	4.56	5.00	5.58	6.45	7.90
025	MS.550	MS.546	MS.548	MS.380	0.94	3.60	4.42	5.10	5.70	6.24	6.98	8.06	9.87
027	MS.550	MS.546	MS.548	MS.390	0.99	3.89	4.76	5.50	6.15	6.74	7.53	8.70	10.65
03	MS.550	MS.546	MS.548	MS.400	1.03	4.33	5.30	6.12	6.84	7.49	8.38	9.67	11.85
034	MS.550	MS.546	MS.548	MS.410	1.07	4.90	6.00	6.93	7.75	8.49	9.49	10.96	13.42
035	MS.550	MS.546	MS.548	MS.420	1.11	5.05	6.18	7.14	7.98	8.74	9.77	11.29	13.82
038	MS.550	MS.546	MS.548	MS.440	1.15	5.48	6.71	7.75	8.66	9.49	10.61	12.25	15.00
04	MS.550	MS.546	MS.548	MS.450	1.19	5.77	7.06	8.16	9.12	9.99	11.17	12.90	15.80
045	MS.550	MS.546	MS.548	MS.470	1.26	6.49	7.95	9.18	10.26	11.24	12.57	14.51	17.77
05	MS.550	MS.546	MS.548	MS.480	1.33	7.21	8.83	10.20	11.40	12.49	13.96	16.12	19.75
055	MS.550	MS.546	MS.548	MS.500	1.39	7.93	9.71	11.22	12.54	13.74	15.36	17.73	21.72
06	MS.550	MS.546	MS.548	MS.520	1.46	8.65	10.60	12.24	13.68	14.99	16.75	19.35	23.69
065	MS.550	MS.546	MS.548	MS.530	1.51	9.37	11.48	13.26	14.82	16.23	18.15	20.96	25.67
070	MS.550	MS.546	MS.548	MS.540	1.58	10.09	12.36	14.28	15.96	17.48	19.55	22.57	27.64
074	MS.550	MS.546	MS.548	MS.550	1.62	10.67	13.07	15.09	16.87	18.48	20.66	23.86	29.22
08	MS.550	MS.546	MS.548	MS.570	1.69	11.54	14.13	16.31	18.24	19.98	22.34	25.80	31.59
087	MS.550	MS.546	MS.548	MS.580	1.76	12.54	15.36	17.74	19.83	21.72	24.29	28.04	34.35
089	MS.550	MS.546	MS.548	MS.590	1.78	12.83	15.72	18.15	20.29	22.23	24.85	28.69	35.14
10	MS.550	MS.546	MS.548	MS.600	1.88	14.41	17.65	20.38	22.79	24.97	27.91	32.23	39.47
11	MS.550	MS.546	MS.548	MS.620	1.97	15.86	19.42	22.42	25.07	27.46	30.70	35.45	43.42
124	MS.550	MS.546	MS.548	MS.640	2.09	17.87	21.89	25.28	28.26	30.96	34.61	39.97	48.95
131	MS.550	MS.546	MS.548	MS.650	2.15	18.89	23.13	26.71	29.86	32.71	36.57	42.23	51.72
139	MS.550	MS.546	MS.548	MS.660	2.22	20.04	24.54	28.34	31.68	34.70	38.80	44.80	54.87
15	MS.550	MS.546	MS.548	MS.670	2.30	21.62	26.48	30.58	34.19	37.45	41.87	48.35	59.22
165	MS.550	MS.546	MS.548	MS.690	2.41	23.79	29.13	33.64	37.61	41.20	46.06	53.19	65.14
174	MS.550	MS.546	MS.548	MS.700	2.48	25.08	30.72	35.47	39.66	43.45	48.57	56.09	68.69
183	MS.550	MS.546	MS.548	MS.710	2.55	26.38	32.31	37.31	41.71	45.69	51.08	58.99	72.24
20	MS.550	MS.546	MS.548	MS.720	2.66	28.83	35.31	40.78	45.59	49.94	55.84	64.47	78.96
218	MS.550	MS.546	MS.548	MS.740	2.77	31.43	38.49	44.44	49.69	54.43	60.86	70.27	86.07
25	MS.550	MS.546	MS.548	MS.760	2.96	36.04	44.14	50.97	56.99	62.43	69.80	80.60	98.71
294	MS.550	MS.546	MS.548	MS.790	3.22	42.38	51.91	59.94	67.01	73.41	82.07	94.77	116.06
310	MS.550	MS.546	MS.548	MS.800	3.30	44.69	54.73	63.20	70.66	77.40	86.54	99.93	122.39

Connection code	Connection	P <sub>max</sub> [bar]
A3.00	BSPT	approx. 700
A3.07	NPT	approx. 700
A3.29	Retaining nut	approx. 300

Example for ordering: Nozzle code + Flow rate code + Connection code = Ordering no.  
 MS.550 + MS.360 + A3.07 = MS.550.360.A3.07  
 (Solid stream; 4.52 l/min. at 100 bar; 1/8 NPT)

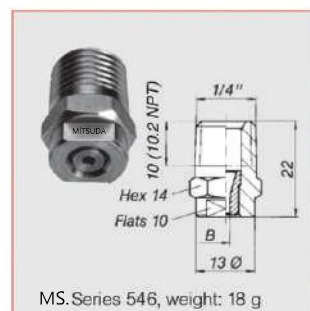

## Quick Coupling

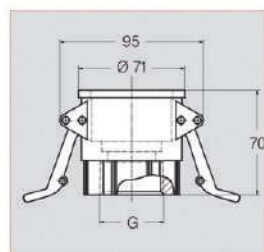

Ordering no.	Material	G	Colour
MC.092.300.53.32.D0	PP	1 1/4 BSPT	Blue
MC.092.301.53.40.D0	PP	1 1/2 NPT	Purple

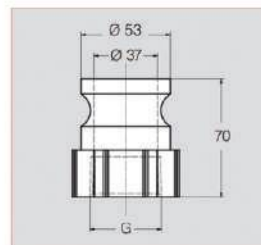

Ordering no.	Material	G	Colour
MC.092.300.53.32.A0	PP	1 1/4 BSPT	Blue
MC.092.301.53.40.A0	PP	1 1/2 NPT	Purple

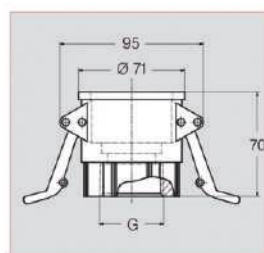

Ordering no.	Material	G	Colour
MC.092.300.53.32.DA	PP	1 1/4 BSPT	Blue
MC.092.301.53.40.DA	PP	1 1/2 NPT	Purple

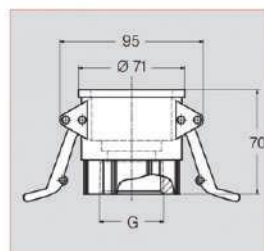

Ordering no.	Material	G	Colour
MC.092.300.53.32.SS	SS	1 1/4 BSPT	SS
MC.092.301.53.40.SS	SS	1 1/2 NPT	SS

## Pipe spacer



Ordering no.	Material	G	Dimensions (mm)		Colour
			L	ØD	
MR.092.400.53.25.00	PP/301 SS	1" (32.0-34.5 mm)	75	25	Blue
MR.092.400.53.32.00	PP/301 SS	1 1/4" (40.0-43.0 mm)	79	32	Blue
MR.092.400.53.40.00	PP/301 SS	1 1/2" (46.0-49.0 mm)	83	40	Blue
MR.092.400.53.50.00	PP/301 SS	2" (58.0-62.0 mm)	89	50	Blue

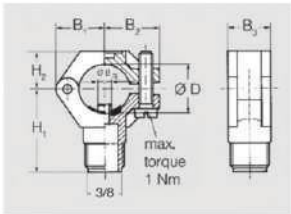

### Retaining nuts

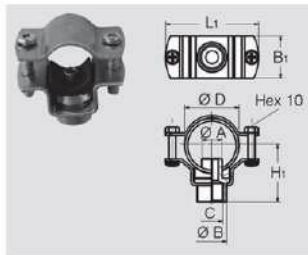

For series	Ordering no.				Screw (Material)	Dimensions [mm]										Weight (Polyamide)
	Type	Material no.				BSPP	Pipe Ø	D Ø	B <sub>R</sub> * Ø	B <sup>**</sup> Ø	B <sub>1</sub>	B <sub>2</sub>	B <sub>3</sub>	H <sub>1</sub>	H <sub>2</sub>	
		Polyamide	Polypropylene	PVDF												
302/684/652	M.090.053	○	○	○	304 SS	3/8	3/8"	16.5-18.0	6.0	6.2-6.4	19.0	22.0	18.5	34.5	14.5	20 g
	M.090.003	○	○	○		3/8	1/2"	20-22.0	6.0	6.2-6.4	21.2	23.8	18.5	36.5	16.5	20 g
	M.090.013	○	○	○		3/8	3/4"	25-27.5	7.6	7.8-8.0	24.5	26.5	22.0	39.5	17.5	25 g
	M.090.023	○	○	○		3/8	1"	32-34.5	10.6	10.8-11.0	30.0	31.0	22.0	44.0	21.0	32 g
	M.090.033	○	○	○		3/8	1 1/4"	40-43.0	12.6	12.8-13.0	34.0	35.5	25.0	48.0	25.0	38 g

For Series	Ordering no.					BSPP	Dimensions [mm]				Weight (Brass)	
	Type	Material no.					H <sub>1</sub>	H <sub>2</sub>	D	Hex		
		16	17	30	56							5E
652/660/684	M.065.200	○	○	○	-	-	3/8	13.0	10.0	12.8	22	25 g
	M.065.200	-	-	-	○	○	3/8	14.5	11.5	12.8	22	

For series	Ordering no.				Dimensions						
	Type	Female thread (C)			Pipe O	D	L <sub>1</sub>	B <sub>1</sub>	H <sub>1</sub>	A Ø	B Ø
		1/8"	1/4"	3/8"							
All nozzles with 1/8", 1/4" or 3/8" male thread	M.090.000.16	AB	AD	-	1/2"	20-22.0	52	30	32	7	18
	M.090.010.16	AB	AD	-	3/4"	25-27.5	56	25	34.5	7	18
	M.090.020.16	-	AD	AF	1"	32-34.5	58	30	39	7	18
	M.090.030.16	-	AD	AF	1 1/4"	40-43.0	70	37	46.5	17.5	25.4

For series	Ordering no.				Screw (Material)	Pipe Ø	D Ø [mm]	Dimensions [mm]						Weight		
	Type	Material no.						Code	H <sub>1</sub>	H <sub>2</sub>	B <sub>R</sub> * Ø	B <sup>**</sup> Ø	B <sub>1</sub>		B <sub>2</sub>	B <sub>3</sub>
		Polyamide	Polypropylene	PVDF												
302 bayonet 422 bayonet/TR 468/548/646 652/679/684	M.090.003	○	○	○	-	1/2"	20-22.0	49.5	16.5	6.0	6.2-6.4	21.2	23.8	18.5	22 g	
	M.090.013	○	○	○	-	3/4"	25-27.5	52.5	17.5	7.6	7.8-8.0	24.5	26.5	22.0	26 g	
	M.090.023	○	○	○	-	1"	32-34.5	57.0	21.0	10.6	10.8-10.0	30.0	31.0	22.0	32 g	

**Example for ordering:** Type M.090.053 + Material no. 51 = Ordering no. M.090.053.51



**Threaded**

Size	A	Q	Kg
1"	140.0	53.0	
1 1/4"	160.0	63.0	
1 1/2"	170.0	63.0	
2"	192.0	76.0	
2 1/2"	220.0	910.0	



**Welded**

Size	A	Q	Kg
1"	72.0	53.0	
1 1/2"	85.0	63.0	
2"	87.0	91.0	
2 1/2"	102.0	100.0	



**Rotary**

Nozzle Model	Join NPT Or BSPT (Female)	A (mm)	B (mm)	C (mm)	Hexagon (mm)	Net Weight (Kg)
21400	3/4 inch	127	105	42	44.5	0.45
18250	3/4 inch	122	100	55	44.5	0.68

**Technical Parameter**

Size	Pressure (bar)	Cleaning radius(m)	Fluxation m/h
1" 1.5"	2	1.25	12
2"	2	1.5	38
2.5"	2	2.0	38

**Technical Parameter**

Size	Pressure (bar)	Cleaning radius(m)	Fluxation m/h
1"	2.5	1.0 1.3	17/10
1 1/4" 1 1/2"	2.5	1.3 1.8	23/17
2"	3.5	2.0 3.0	55/38
2 1/2"	3.5	3.0 3.5	58/41

Nozzle Order Number	Capacity (L/min)					
	1 bar	1.5 bar	2 bar	2.5 bar	3 bar	4 bar
21400-HSS10-SS	23	28	32	36	39	46
21400-HSS18-SS	41	50	58	65	71	82
18250-HSS21-SS	48	59	68	76	83	96
18250-HSS45-SS	103	126	145	162	178	205

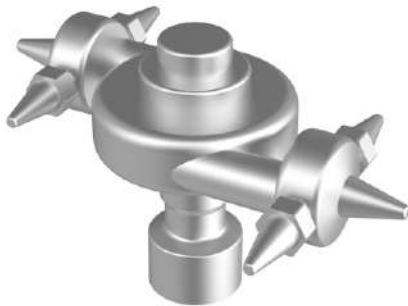

Size	A	H	Pressure (bar)	Cleaning radius(m)	Fluxation m/h	Kg
1"	118.0	165.0	1.5 2.0	2.0 3.0	23	
1 1/2"	142.0	189.0	1.8 2.5	2.5 3.0	38	
2"	145.0	191.0	2.5 3.0	3.5 4.0	60	

Nozzle Order NO.	Performance Data of Tankjet 19250 tank cleaning nozzle					
	Flow (L/min)					
	1.5 bar	3 bar	4 bar	5 bar	6 bar	8 bar
19250.STCN5-316SS	14	19.7	23	25	28	32
19250.STCN5.7-316SS	15.9	22	26	29	32	37
19250.STCN7-316SS	19.5	28	32	36	39	45
19250.STCN8-316SS	22	32	36	41	45	52
19250.STCN10-316SS	28	39	46	51	56	64

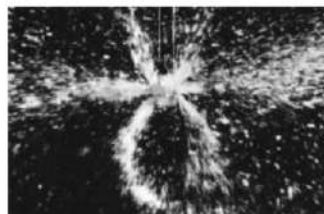

## Bayonet quick-release system

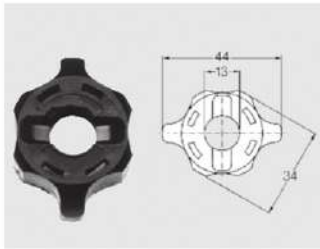
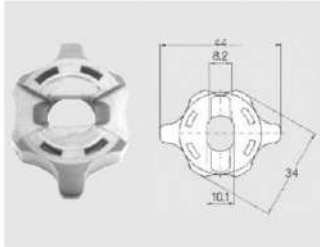

For series	Ordering no.	Material	Colour
	652	<b>M.065. 202. 56. 00</b>	POM
<b>M.065. 202. 53. 00</b>		Polypropylene	grey
<b>M.065. 202. 5E. 00</b>		PVDF	blue
548/684	<b>M.065. 202. 56. 11</b>	POM	black
	<b>M.065. 202. 53. 11</b>	Polypropylene	grey

Ordering no.	Material	Colour
<b>M.065. 202. 56. 40</b>	POM	beige
<b>M.065. 202. 53. 40</b>	Polypropylene	grey

## Bayonet-Nipple

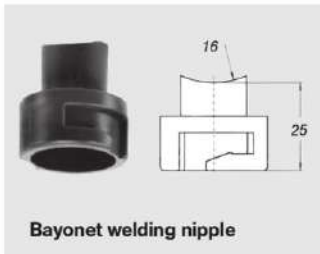

For series	Ordering no.	Material	Twist angle to the pipe axis	
			Angle	Direction
646/652/684	<b>M. 095 .016. 50. 10. 85</b>	PVC	0°	
	<b>M. 095 .016. 53. 08. 05</b>	PP	10°	right
	<b>M. 095 .016. 53. 09. 29</b>	PP	10°	left
	<b>M. 095 .016. 53. 09. 99</b>	PP	35°	right
	<b>M. 095 .016. 53. 09. 98</b>	PP	35°	left
	<b>M. 095 .016. 53. 07. 36</b>	PP	45°	right
	<b>M. 095 .016. 53. 09. 30</b>	PP	45°	left
	<b>M. 095 .016. 53. 10. 87</b>	PP	55°	right
	<b>M. 095 .016. 53. 10. 88</b>	PP	55°	left

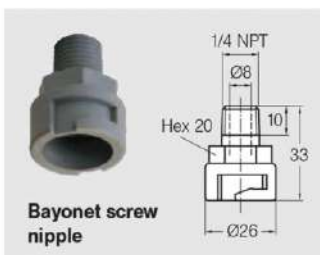

For series	Ordering no.	Material	Connection
652 684	<b>M. 090. 075. 53. 00</b>	PP	1/4 NPT

## Ball joint for bayonet quick-release system

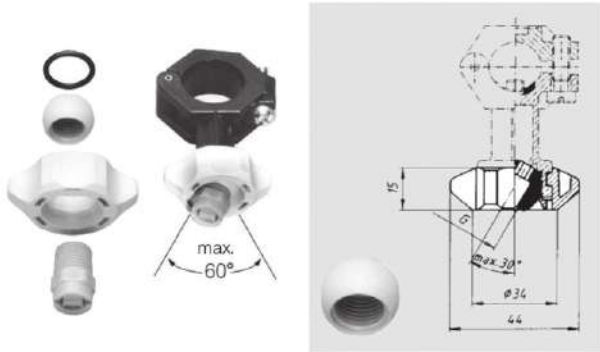

For series	Ordering no.			Colour
	Type	Mat no.	Code	
		5E		
For all nozzle with 1/8"- or 1/4"-male thread.	M.092.150	PVDF	1/8 BSPP	blue
			1/4 BSPP	

T	P <sub>max</sub>
65° C	10 bar
80° C	8 bar
100° C	4 bar



For series	Ordering no.	Material	Colour
For ball joint	M. 092. 150. 5E. 00	PVDF	blue

## Compact ball joints for narrow installation conditions

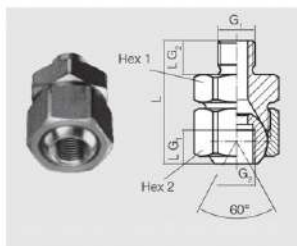

For series	Ordering no.			Dimensions [mm]							Weight (Brass)	
	Type	Material no.		Code	G <sub>1</sub> BSPP	G <sub>2</sub> BSPP	L <sub>G1</sub>	L <sub>G2</sub>	L	Hex <sub>1</sub>		Hex <sub>2</sub>
		16	30									
For all nozzles with 1/8"- male thread.	M. 092. 010	303 SS	Brass	AA	1/8	1/8	8.0	8.0	29.3	22	22	70 g
	M. 092. 024			AC	1/4	1/4	12.0	12.0	44	27	27	140 g
	M. 092. 030			AE	3/8	3/8	12.0	12.0	44	27	30	160 g

**Example**      Type      + Material no.      + Code      =      Ordering no.  
 for ordering: M. 092. 010      + 16                              + CA      =      M. 092.010.16.AA





### Design Features

#### Easy nozzle replacement

Easy dismantling nozzle design, the nozzle and spray head can be quickly dismantled that you can rotate the spray head by 90 degree to install it or split it from nozzle by hand. So it can significantly downtime during maintenance.

#### Auto orienting spray head

There is an interior block, which can keep nozzle in right position without manual adjustment. Therefore, it can avoid quality problem caused by wrong orientation of nozzle.

#### Anti-corrosion and wearable

Easy split nozzle; Made of Glass Fiber PP (25%), Carbon Fiber PP (40%) and PVDF, featured high intensity, wearability and anticorrosion, Suitable for washing and rinsing of corrosive, such as phosphate, acid & solvent; Max temperature for Glass Fiber PP is 82 C; Max temperature for Carbon Fiber is 120 C; While PVDF is high pure without pigment which can keep high purity is processing, and the max temperature is 148 C under 7 kg pressure.

#### Widely capacity choice

Available sizes: 1/8, 1/4" and 3/8" ; Absolutely windtight between nozzle and spray head with a interior O-shaped NBR windtight circle; Easy Split Nozzle: Special appearance of spray head for grasp; Available spray head shapes: MQC flat fan, MQB full cone and MQA hollow cone; and various capacities angles are available.



### Performance Data



Easy-dismantling Flat Fan Spray Tip

Nozzle type (Spraying angle under 3 bar pressure)					Capacity (L/min)								
50°	65°	80°	90°	110°	0.3 bar	1 bar	2 bar	3 bar	4 bar	5 bar	6 bar	7 bar	14 bar
MQC5001	MQC6501	MQC8001	MQC9501	MQC11001	0.12	0.23	0.32	0.39	0.46	0.51	0.56	0.60	0.85
MQC5002	MQC6502	MQC8002	MQC9502	MQC11002	0.25	0.45	0.64	0.79	0.91	1.0	1.1	1.2	1.7
MQC5003	MQC6503	MQC8003	MQC9503	MQC11003	0.37	0.69	0.97	1.2	1.4	1.5	1.7	1.8	2.6
MQC5004	MQC6504	MQC8004	MQC9504	MQC11004	0.50	0.92	1.3	1.6	1.8	2.0	2.2	2.4	3.4
MQC5005	MQC6505	MQC8005	MQC9505	MQC11005	0.62	1.1	1.6	2.0	2.3	2.5	2.8	3.0	4.3
MQC5006	MQC6506	MQC8006	MQC9506	MQC11006	0.75	1.3	1.9	2.4	2.7	3.1	3.3	3.6	5.1
MQC5008	MQC6508	MQC8008	MQC9508	MQC11008	1.0	1.8	2.6	3.2	3.6	4.1	4.5	4.8	6.8
MQC5010	MQC6510	MQC8010	MQC9510	MQC11010	1.2	2.3	3.2	3.9	4.6	5.1	5.8	6.0	8.5
MQC5015	MQC6515	MQC8015	MQC9515	MQC11015	1.9	3.4	4.8	5.9	6.8	7.6	8.4	9.0	12.8
MQC5020	MQC6520	MQC8020	MQC9520	MQC11020	2.5	4.6	6.5	7.9	9.1	10.2	11.2	12.1	17.1
MQC5030	MQC6530	MQC8030	MQC9530	MQC11030	3.7	6.8	9.7	11.8	13.7	15.3	16.7	18.1	26



Easy-dismantling Full Cone Spray Tip

Nozzle type	Capacity (L/min)						Spray angle						
	0.5 bar	0.7 bar	1.5 bar	2 bar	3 bar	4 bar	5 bar	6 bar	7 bar	10 bar	0.5 bar	1.5 bar	6 bar
MQB1	0.25	0.38	0.54	0.62	0.74	0.85	0.94	1.0	1.1	1.3	-	58°	53°
MQB2	0.65	0.76	1.0	1.2	1.5	1.7	1.9	2.0	2.2	2.6	43°	50°	46°
MQB3	0.98	1.1	1.6	1.9	2.2	2.5	2.8	3.1	3.3	3.9	52°	65°	59°
MQB3.5	1.1	1.3	1.9	2.2	2.6	3.0	3.3	3.6	3.9	4.5	43°	50°	46°
MQB5	1.6	1.9	2.7	3.1	3.7	4.2	4.7	5.1	5.5	6.5	52°	65°	59°
MQB3.5	2.1	2.5	3.5	4.0	4.8	5.5	6.1	6.7	7.1	8.4	45°	50°	46°
MQB10	3.3	3.8	5.4	6.2	7.4	8.5	9.4	10.2	11.0	13.0	58°	67°	61°

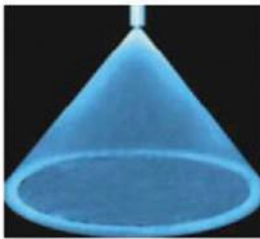

Hollow cone

Nozzle type	Capacity (L/min)										Spray angle		
	0.2 bar	0.5 bar	1 bar	1.5 bar	2 bar	3 bar	4 bar	5 bar	6 bar	7 bar	0.5 bar	1.5 bar	6 bar
MQA0.A	-	0.16	0.23	0.28	0.32	0.39	0.46	0.51	1.56	0.60	-	58°	69°
MQA1	-	0.32	1.46	0.56	0.64	0.79	0.91	1.0	1.1	1.2	-	65°	76°
MQA2	-	0.64	0.91	1.1	1.6	1.6	1.8	2.0	2.2	2.4	53°	70°	80°
MQA3	-	0.97	1.4	1.7	1.9	2.4	2.7	3.1	3.3	3.6	55°	79°	80°
MQA5	-	1.6	2.3	2.8	3.2	3.9	4.6	5.1	5.6	6.0	70°	75°	79°
MQA8	1.6	2.6	3.6	4.5	5.2	6.3	7.3	8.2	8.9	9.6	65°	72°	74°
MQA10	2.0	3.2	4.6	5.6	6.4	7.9	9.1	10.2	11.2	12.1	70°	76°	75°
MQA15	3.1	4.8	6.8	8.4	9.7	11.8	13.7	15.3	16.7	18.1	70°	72°	75°
MQA5W	-	1.6	2.3	2.8	3.2	3.9	4.6	5.1	5.6	6.0	125°	112°	98°
MQA8W	1.6	2.6	3.6	4.5	5.2	6.3	7.3	8.2	8.9	9.6	112°	100°	87°
MQA10W	2.0	3.2	4.6	5.6	6.4	7.9	9.1	10.2	11.2	12.1	111°	97°	89°
MQA15W	3.1	4.8	6.8	8.4	9.7	11.8	13.7	15.3	16.7	18.1	110°	98°	90°

### Common Application

- | PCB
- | Wash & Rinse
- | Phosphatization for metal parts
- | Cooling
- | Moistening
- | Chemical Manufacture
- | Dust removing

### Ordering info

Nozzle type	Nozzle Inlet Conn. (inch)
MQJ1 / 8	1/8
MQJ1 / 4	1/4
MQJJB1 / 4	1/4 (angle fitting)
MQJ3 / 8	3/8

Please mark our nozzle model and spray tip model  
For example:

Nozzle Model: MQJ1 1/4-PP

Spray tip model: MQB5-PP

Complete nozzle model: MQJ1/4-PP+MQB-PP



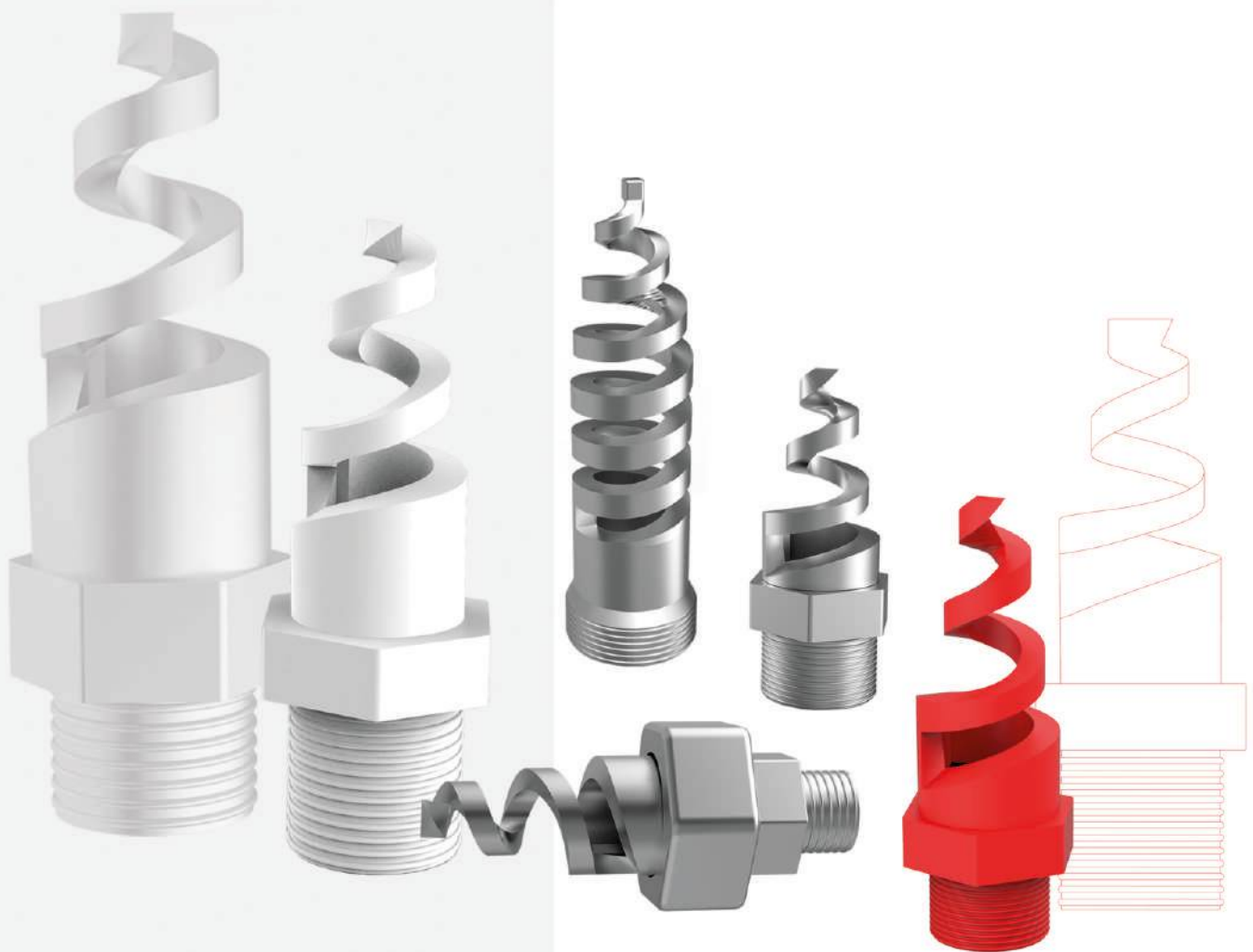

# Spiral Nozzles MT.LEM



## DESIGN FEATURES

Nozzles placed on the cluster are Mitsuda MT series spiral nozzles designed with clog resistant features.  
They can be combined with all other Mitsuda nozzles according to required process through female connection.

## SPRAY CHARACTERISTICS

Multidirectional coverage through six nozzles placed on the cluster in perfect angles.  
Flow rates from 4.2 to 157 gmp (Other required flow rates can also be supplied if needed).  
Please check tables for approximate dimensions.

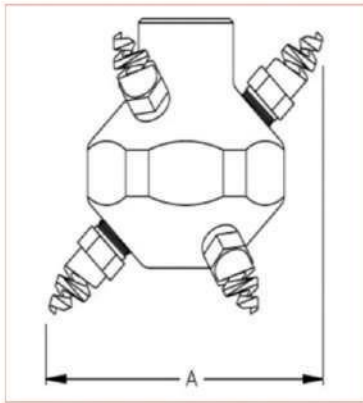

LEM Coverage Chart			
When Spraying at 40 - 50 PSI			
Female Pipe Size	Nozzle Number	Sucrubbing Diameter	Rinsing Diameter
3/4	MT.LEM 6	1.6	3.1
	MT.LEM 8	2.1	6.1
	MT.LEM 10	4.6	9.1
1	MT.LEM 12	6.6	13.1
	MT.LEM 14	6.9	13.6
	MT.LEM 16	7.3	14.6
	MT.LEM 18	8.1	16.1

Dimensions are approximate. Check with MITSUDA for critical dimension applications.

MT.LEM Coverage Chart												
Spherical, 360° Spray Angle, 3/4" and 1" Pipe Sizes												
Female Pipe Size	Nozzle Number	K Factor	GALLONS PER MINUTE @ PSI							Minimum Entrance Open(in.) A	Weight	
			10 PSI	20 PSI	30 PSI	40 PSI	60 PSI	80 PSI	100 PSI		Metal	Plas.
3/4	MT.LEM 6	1.34	4.21	5.95	7.28	8.41	10.3	12.0	13.4	4.51	2.26	6.01
	MT.LEM 8	2.54	8.01	11.4	14.0	16.1	19.6	22.7	25.4			
	MT.LEM 10	3.96	12.6	17.8	21.8	25.1	30.6	35.5	39.6			
1	MT.LEM 12	5.70	18.1	25.6	31.3	36.1	44.1	51.0	57.0	5.26	4.13	11.1
	MT.LEM 14	7.69	24.4	34.5	42.2	48.7	59.5	68.8	76.9			
	MT.LEM 16	9.97	31.6	44.6	54.7	63.1	77.2	89.2	99.7			
	MT.LEM 20	15.8	49.6	70.1	85.8	99.1	121	141	158			

# Spiral Nozzles MS.TW



### DESIGN FEATURES

- | Tank Washing Nozzle
- | Spiral design
- | Clog resistant
- | Designed for more energy saving
- | Placing on small holes.

### SPRAY CHARACTERISTICS

- | Easy maintenance
- | Designed to spray in opposite directions
- | Flow rates from 11.4 to 260 l/min.

Tank Washing TW Coverage Chart When Spraying at 2 - 3 bar			
Pipe Size	Nozzle Number	Sucrubbing Diameter(mm)	Rinsing Diameter(mm)
3/8	MS.TW12	381	761
	MS.TW14	481	1201
	MS.TW16	611	1501
	MS.TW20	911	2101
1	MS.TW1	2401	6101

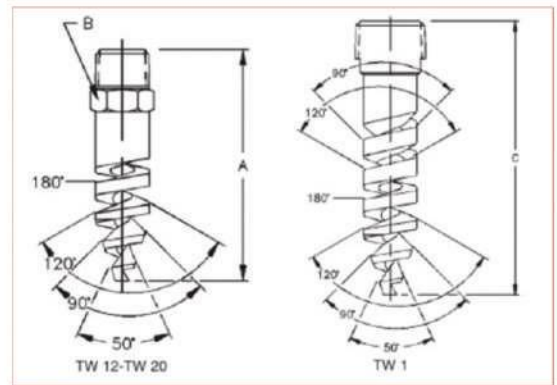

Tank Washing TW Flow Rates and Dimensons TW 180° and 270° Spray Angles 3/8 1" Sizes, BSP or NPT															
Male Pipe Size	Nozzle Number	Available Spray Angles	K Factor	LITERS PER MINUTE						Approx(mm)		Metal Only Dim.(mm)			Weight (g) Metal
				0.7 bar	1 bar	2 bar	3 bar	4 bar	5 bar	Orifice Dia	Free Pass Dia.	A	B	C	
3/8	MS.TW12	180 270	13.8	11.5	13.8	19.4	23.8	27.4	30.7	4.84	3.31	73.1	17.6	49.7	
	MS.TW14	180 270	18.6	15.5	18.6	26.2	32.1	37.0	41.4	5.60	3.31				
	MS.TW16	180 270	24.3	20.3	24.3	34.3	41.9	48.4	54.1	6.36	3.31				
	MS.TW20	180 270	37.7	31.6	37.7	53.3	65.2	75.3	84.2	7.88	3.31				
1	MS.TW1	270	117	97.3	117	165	202	233	261	14.3	5.09			146.2	299

# Spiral Nozzles MS.TF

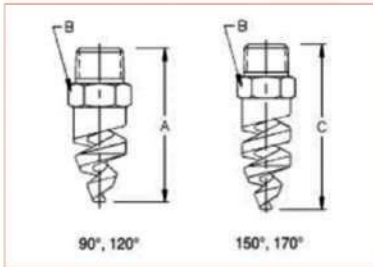

## DESIGN FEATURES

- ✓ Clog resistant
- ✓ More Energy saving
- ✓ Designed without any internal parts
- ✓ Designed to provide more fluid discharge velocity
- ✓ Male connection.

## SPRAY CHARACTERISTICS

- ✓ Full cone spraying
- ✓ Spray angles from 50° to 180°
- ✓ Flow rates from 0.5 to 3220 gmp (For higher flow rates please contact with our team).

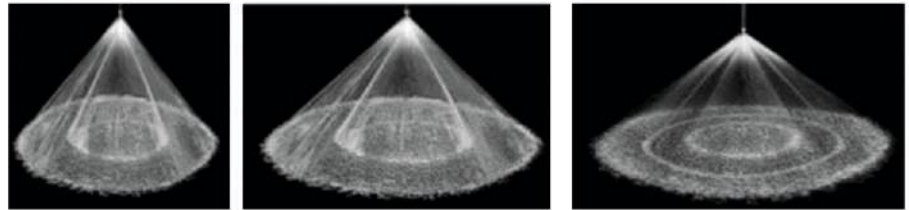
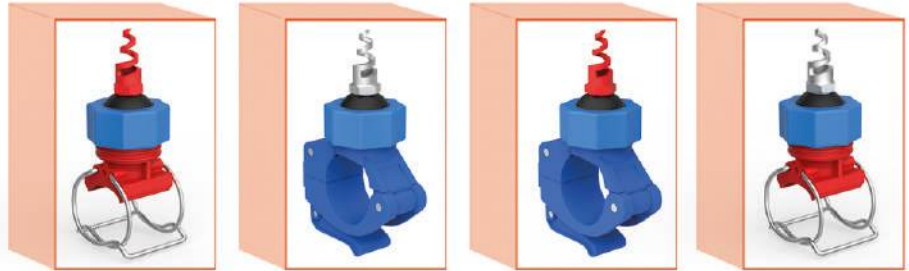

Full Cone 60°(NN)

Full Cone 90°(FCN)

Full Cone 150°-170°

Male Pipe Size	Nozzle Number	Available Spray Angles	K Factor	GALLONS PER MINUTE @ PSI												Approx (in.)		Dim. (in.) for Metal Only*			Wt. (oz.)	
				5 PSI	10 PSI	20 PSI	30 PSI	40 PSI	50 PSI	60 PSI	80 PSI	100 PSI	200 PSI	400 PSI	Orif. Dia.	Free Pass Dia.	A"	B	C	60° Metal	90° 120° Plas.	
1/8	MS.TF6	60° 90° 120° 150° 170°	0.222	0.496	0.71	1.00	1.23	1.41	1.58	1.72	1.99	2.22	3.12	4.44	0.10	0.10	1.70	1.57	1.70	1.01	0.21	
	MS.TF8	60° 90° 120° 150° 170°	0.412	0.920	1.31	1.85	2.27	2.61	2.92	3.19	3.69	4.12	5.82	8.23	0.14	0.14	1.70	1.57	2.20			
1/4	MS.TF6	60° 90° 120° 150° 170°	0.222	0.496	0.71	1.00	1.23	1.41	1.58	1.72	1.99	2.22	3.14	4.44	0.10	0.10	1.89	1.57	1.89			
	MS.TF8	60° 90° 120° 150° 170°	0.412	0.920	1.31	1.85	2.27	2.61	2.92	3.19	3.69	4.12	5.82	8.23	0.14	0.14	1.89	1.57	2.39	1.57	0.21	
	MS.TF10	60° 90° 120° 150° 170°	0.533	1.42	2.01	2.84	3.48	4.01	4.48	4.91	5.67	6.33	8.95	12.7	0.17	0.14	1.89	1.57	2.39			
3/8	MS.TF6	60° 90° 120°	0.222	0.496	0.71	1.00	1.22	1.41	1.58	1.72	1.99	2.22	3.14	4.44	0.20	0.10						
	MS.TF8	60° 90° 120°	0.412	0.920	1.31	1.85	2.25	2.61	2.92	3.19	3.69	4.12	5.82	8.23	0.20	0.14						
	MS.TF10	60° 90° 120°	0.632	1.42	2.01	2.84	3.46	4.01	4.48	4.91	5.67	6.33	8.95	12.7	0.20	0.14						
	MS.TF12	60° 90° 120° 150° 170°	0.949	2.12	3.01	4.25	5.20	6.02	6.72	7.36	8.50	9.50	13.5	19.1	0.20	0.14	1.89	0.70	2.39	1.64	0.26	
	MS.TF14	60° 90° 120° 150° 170°	1.29	2.87	4.06	5.74	7.01	8.11	9.07	9.93	11.6	12.9	18.2	25.7	0.23	0.14						
1/2	MS.TF24	60° 90° 120° 150° 170°	3.82	8.53	12.2	17.1	20.9	24.2	27.0	29.6	34.2	38.2	54.0	76.3	0.39	0.20	2.51	0.89	3.07	3.01	0.51	
	MS.TF28	60° 90° 120° 150° 170°	5.23	11.8	16.6	23.4	28.6	33.1	37.0	40.5	46.8	52.3	73.9	105	0.45	0.20						
3/4	MS.TF32	60° 90° 120° 150° 170°	6.65	14.9	21.1	29.8	36.4	42.1	47.1	51.5	59.5	66.5	94.0	134	0.51	0.20	2.76	1.14	3.51	5.51	0.89	
1	MS.TF40	60° 90° 120° 150° 170°	10.7	23.8	33.6	47.5	58.0	67.1	75.0	82.2	94.9	107	151	213	0.64	0.26	3.64	1.39	4.39	8.51	2.51	
	MS.TF48	60° 90° 120° 150° 170°	15.1	33.7	47.6	67.3	82.3	95.1	107	117	135	151	213	301	0.76	0.26						
1 1/2	MS.TF56	60° 90° 120° 150° 170°	20.5	45.7	64.6	91.3	112	130	145	159	183	205	289	409	0.89	0.32			5.39			
	MS.TF64	60° 90° 120° 150° 170°	26.8	59.8	84.6	121	146	170	190	208	240	268	379	535	1.01	0.32	4.39	2.01	5.39	22.1	4.26	
	MS.TF72	60° 90° 120° 150° 170°	30.5	68.0	96.1	137	166	192	216	236	273	305	430	608	1.14	0.32			5.64			
2	MS.TF88	60° 90° 120° 150° 170°	44.4	99.0	141	200	242	281	314	344	397	444	627	886	1.39	0.45	5.64	2.51	5.89	46.1	8.01	
	MS.TF96	60° 90° 120° 150° 170°	56.0	125	178	252	306	355	396	434	501	560	792	1121	1.51	0.45	6.89	2.51	7.01	54.1	9.01	
3	MS.TF112	60° 90° 120° 150° 170°	81.1	181	260	365	443	513	573	628	725	811	1151	1621	1.76	0.57						
	MS.TF128	60° 90° 120° 150° 170°	108	239	337	482	588	680	759	832	961	1071	1511	2151	2.01	0.57	8.64	3.51	9.26	115	20.1	
4	MS.TF160	60° 90° 120°	167	372	526	744	909	1051	1171	1291	1481	1661	2351	3321	2.51	0.64	10.2	4.51		170	27.1	

# Spiral Nozzles MS.ST



## DESIGN FEATURES

- Designed with Cobalt Alloy 6 or RBSC ceramic parts against wearing
- Clog resistant
- More energy saving
- Designed without any internal parts
- Both male and female connections.

## SPRAY CHARACTERISTICS

- Full cone spraying (Hollow Cone available upon request)
- Perfect atomization
- Spray angles from 50° to 180°
- Flow rates from 0.5 to 3220 gmp (For higher flow rates please contact with our team).

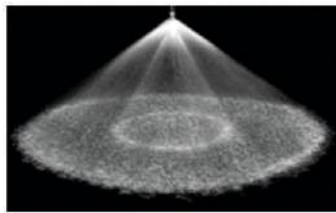
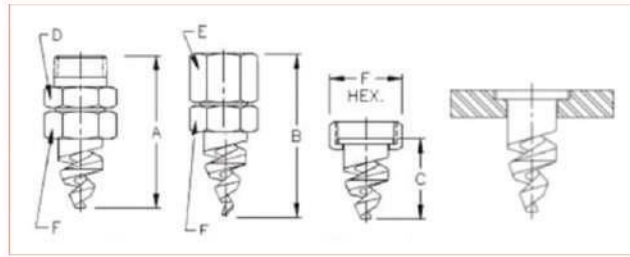

Full Cone 120° (FFN)

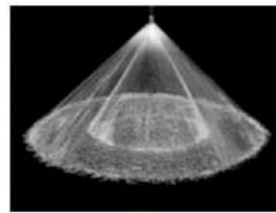

Full Cone 90° (FCN)



### LEM Coverage Chart

Spherical, 360 Spray Angle, 3/4" and 1" Pipe Sizes

3-piece Male or Female Pipe Size	** 2-piece Female Pipe Size	Nozzle Number	K Factor	GALLONS PER MINUTE @ PSI												Approx. (in.) Orifice Pass Dia. Dia.		Approximate Dimensions (in.)						Wt. (lbs.) Male
				5 PSI	10 PSI	15 PSI	20 PSI	30 PSI	40 PSI	50 PSI	60 PSI	80 PSI	100 PSI	200 PSI	400 PSI			A	B	C	D	E	F	
1/4		MS.ST6	0.222	0.496	0.701	0.858	0.991	1.22	1.41	1.58	1.72	1.99	2.22	3.14	4.44	0.10	0.10	2.57	2.57		0.70	0.70	0.82	0.20
		MS.ST9	0.412	0.920	1.31	1.60	1.85	2.26	2.61	2.92	3.19	3.69	4.12	5.82	8.23	0.14	0.14	2.57	2.57		0.70	0.70	0.82	
		MS.ST10	0.633	1.42	2.01	2.46	2.84	3.47	4.01	4.48	4.91	5.67	6.33	8.95	12.7	0.17	0.14	2.57	2.57		0.70	0.70	0.82	
3/8		MS.ST12	0.950	2.13	3.01	3.68	4.25	5.21	6.01	6.72	7.36	8.50	9.50	13.5	19.1	0.20	0.14	2.95	2.95		0.95	0.95	1.14	1.14
		MS.ST14	1.29	2.87	4.06	4.97	5.74	7.02	8.11	9.07	9.93	11.6	12.9	18.2	25.7	0.23	0.14	2.89	2.89		0.95	0.95	1.14	
		MS.ST16	1.69	3.76	5.31	6.50	7.51	9.19	10.7	12.0	13.1	15.1	16.9	23.8	33.6	0.26	0.14	3.00	3.00		0.95	0.95	1.14	
		MS.ST20	2.62	5.84	8.26	10.2	11.8	14.3	16.6	18.5	20.3	23.4	26.2	37.0	52.3	0.32	0.14	2.89	2.89		0.95	0.95	1.14	
3/4		MS.ST24	3.82	8.53	12.2	14.9	17.1	21.0	24.2	27.0	30.0	34.2	38.2	54.0	76.3	0.39	0.20	3.57	3.57		1.39	1.39	1.51	0.63
		MS.ST28	5.23	11.8	16.6	20.3	23.4	28.7	33.1	37.0	40.5	46.8	52.3	73.9	105	0.45	0.20	3.54	3.54		1.39	1.39	1.51	
		MS.ST32	6.65	14.9	21.1	25.8	29.8	36.5	42.1	47.1	51.5	59.5	66.5	94.0	134	0.51	0.20	3.51	3.51		1.39	1.39	1.51	
1		MS.ST40	10.7	23.8	33.6	41.2	47.5	58.1	67.1	78.0	82.2	94.9	107	151	213	0.64	0.26	4.51	4.51		1.89	1.76	2.01	1.26
		MS.ST48	15.1	33.7	47.6	58.3	67.3	82.3	95.1	107	117	135	151	213	301	0.76	0.26	4.51	4.51		1.89	1.76	2.01	
1 1/2		MS.ST56	20.5	45.7	64.6	79.1	91.3	113	130	145	159	183	205	268	409	0.89	0.32	5.76	5.76		1.95	2.14	2.20	1.76
		MS.ST64	26.8	59.9	84.6	104	121	147	170	190	208	240	268	378	535	1.01	0.32	5.76	5.76		1.95	2.14	2.20	
		MS.ST72	30.5	68.0	96.1	119	137	167	193	216	236	273	305	429	608	1.13	0.32	5.76	5.76		1.95	2.14	2.20	
2	2 1/2 3	MS.ST88	44.4	100	141	172	199	243	261	314	344	397	443	627	886	1.38	0.45	7.64	6.32	4.57	3.01	3.51	3.51	5.01
		MS.ST96	56.0	125	178	217	251	307	355	396	434	501	560	792	1121	1.51	0.45	9.01	7.39	5.64	3.64	4.01	4.01	7.01
3	3	MS.ST112	81.1	182	257	315	363	444	513	573	628	725	811	1151	1621	1.76	0.57	10.4			3.64	4.01	4.01	9.01
		MS.ST128	108	240	340	415	481	589	680	780	832	961	1071	1511	2151	2.01	0.57	10.8		7.29	3.64	4.01	4.01	
4	4	MS.ST160	167	372	525	644	743	910	1051	1171	1291	1481	1661	2350	3321	2.51	0.64	12.0		8.26	4.57	5.01	5.01	14.1

# Spiral Nozzles MS.N



## DESIGN FEATURES

- | Clog resistant
- | Designed without any internal parts
- | Fits pipe sizes 1/2", 1" and 1-1/2" Male connection

## SPRAY CHARACTERISTICS

- | Two spraying cones with wide and narrower angles
- | Full cone spraying
- | Spray angles from 90° to 120°
- | Flow rates from 3.0 to 534 gmp

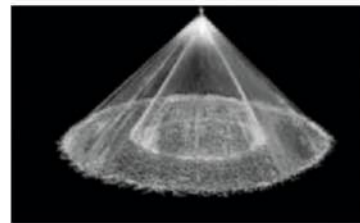
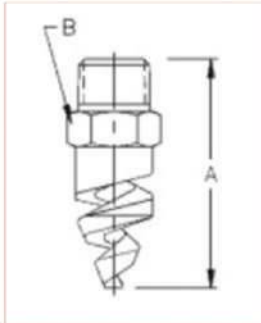

Full Cone 90°

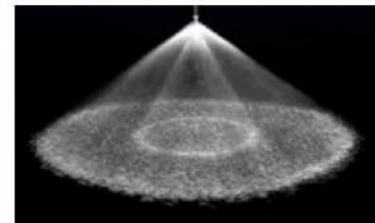

Full Cone 120°(W)

### N Flow Rates and Dimensions

Full Cone, Medium 90° and Wide 120°(W) 1/2" to 1 1/2" Pipe Sizes

Male Pipe Size	Nozzle Number	K Factor	GALLONS PER MINUTE @ PSI									Approx(mm)		Approximate Dimensions (inches)		Weight (g) Metal
			10 PSI	20 PSI	30 PSI	40 PSI	60 PSI	80 PSI	100 PSI	200 PSI	400 PSI	Orifice Dia	Free Pass Dia.			
1/2	MS.N1	0.950	3.01	4.25	5.21	6.01	7.36	8.50	9.50	13.5	19.1	0.20	0.14	2.51	2.51	3.01
	MS.N2	0.69	5.31	7.51	9.19	10.7	13.1	15.1	16.8	23.8	33.6	0.26	0.14			
	MS.N3	2.62	8.26	11.8	14.4	16.6	20.3	23.4	26.2	37.0	52.3	0.32	0.14			
	MS.N4	3.82	12.2	17.1	21.0	24.2	29.6	34.2	38.2	54.0	76.3	0.39	0.20			
	MS.N5	5.23	16.6	23.4	28.9	33.1	40.5	46.8	52.3	73.9	105	0.44	0.20			
	MS.N6	6.65	21.1	29.8	36.5	42.1	51.5	59.4	66.5	94.0	134	0.51	0.20			
1	MS.N6	6.65	21.1	29.8	36.5	42.1	51.5	59.5	66.5	94.0	134	0.51	0.20	3.64	3.64	8.51
	MS.N7	10.7	33.6	47.5	58.1	67.1	82.2	94.9	107	151	213	0.63	0.26			
	MS.N8	15.1	47.6	67.3	82.4	95.1	117	135	151	213	301	0.76	0.26			
1 1/2	MS.N9	20.5	64.5	91.3	113	130	159	183	205	289	409	0.89	0.32	4.39	4.39	27.1
	MS.N10	26.8	84.5	121	147	170	208	240	267	379	535	1.01	0.32			



# Spiral Nozzles MS.TFXPW



## DESIGN FEATURES

- Designed with two-sided spiral nozzle to obtain wide coverage
- One piece without any internal parts also provides wide free passage.

## SPRAY CHARACTERISTICS

- Full cone spraying
- Spray angle of 150°
- Flow rates from 33.6 to 534 gmp.

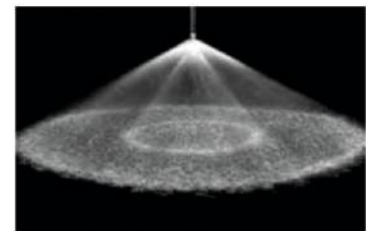
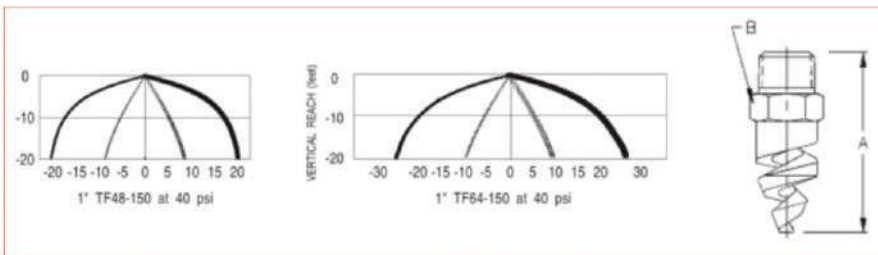
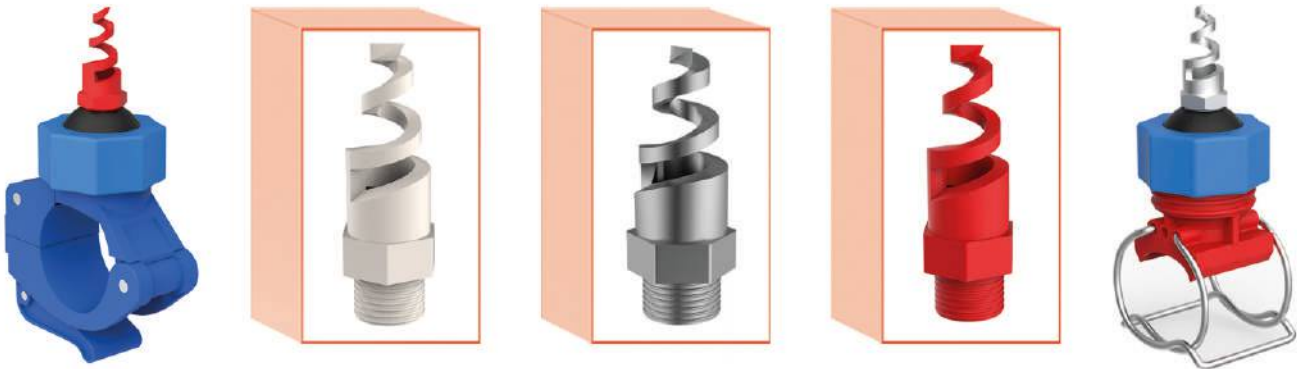

Full Cone 150°

### MS.TFXPW Flow Rates and Dimensions

Full Cone, 150 Wide Spray Angle, 1" & 1-1/2" Pipe Size

Female Pipe Size	Nozzle Number	K Factor	Pressure (PSI)												Approx Free Pass Dia. (in.)	Approx Orifice Dia. (in.)	Approx Dim. (in)		Wt. (lbs.)
			5	10	20	30	40	50	60	80	100	200	400	A			B		
1	MS.TF48XPW	15.1	33.7	47.6	67.3	82.4	95.1	107	117	135	151	213	301	0.51	0.76	6.51	2.26	2.07	
1 1/2	MS.TF64XPW	26.8	59.8	84.6	121	147	170	190	208	240	268	379	535	0.51	1.01	6.76	2.51	2.45	



### DESIGN FEATURES

- Clog resistant
- Designed without any internal parts
- Fits pipe sizes 1/2", 1" and 1-1/2" Male connection.

### SPRAY CHARACTERISTICS

- Full cone spraying
- Spray angles of 90° & 120°
- Flow rates from 96.7 to 1720 l/min
- Two cones with wide and narrower angles to achieve full cone spraying.

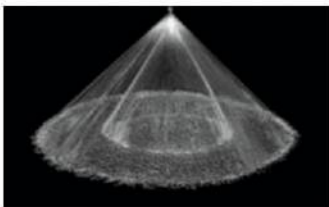

Full Cone 120°

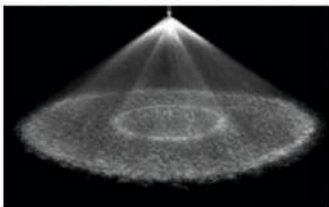
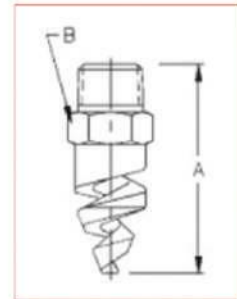

Full Cone 90°

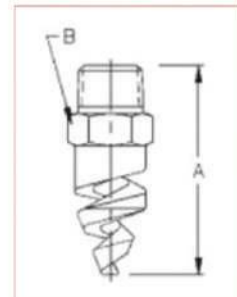

### MS.TFXPW Flow Rates and Dimensions

Full Cone, 150 Wide Spray Angle, 1" & 1-1/2" Pipe Size

Female Pipe Size	Nozzle Number	K Factor	LITERS PER MINUTE @ BAR								Approx (mm)		Approximate Dimensions (mm)		W (g) Metal
			0.5 bar	0.7 bar	1 bar	2 bar	3 bar	5 bar	10 bar	20 bar	Orifice Dia.	Free Pass Dia.			
1/2	MS.N1	13.8	9.68	11.5	13.8	19.4	23.8	30.7	43.3	61.2	4.77	3.19	63.6	22.5	86
	MS.N2	24.3	17.2	20.3	24.3	34.3	41.7	54.0	76.5	109	6.39	3.19			
	MS.N3	37.7	26.7	31.6	37.7	53.3	65.2	84.2	120	169	7.95	3.19			
	MS.N4	55.0	38.9	46.1	55.0	77.8	95.2	124	175	247	9.54	4.77			
	MS.N5	75.2	53.3	63.0	75.3	107	131	169	239	337	11.2	4.77			
	MS.N6	95.8	67.8	90.2	95.8	136	167	215	304	429	12.8	4.77			
1	MS.N6	95.8	67.8	80.2	95.8	136	167	215	304	429	12.8	4.77	92.3	35.2	242
	MS.N7	154	109	129	154	217	265	342	484	684	16.0	6.36			
1 1/2	MS.N8	217	154	182	217	307	376	485	686	969	19.2	6.36	112	50.9	766
	MS.N9	295	209	247	295	417	510	658	931	1321	22.3	7.95			
	MS.N10	386	273	323	386	546	668	862	1221	1721	25.5	7.95			

# Spiral Nozzles MS.TF29-180



## DESIGN FEATURES

- | Designed with two-turn spiral nozzle to obtain very wide coverage
- | Designed without any internal parts
- | Recommended as an appropriate nozzle type if there is a narrow distance between nozzle and material.

## SPRAY CHARACTERISTICS

- | Ultrawide coverage
- | Perfect atomization
- | Spray angles of 180°
- | Flow rates from 3.80 to 110 gmp.

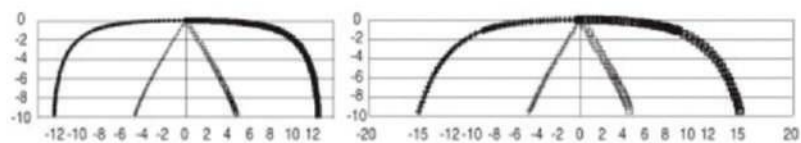
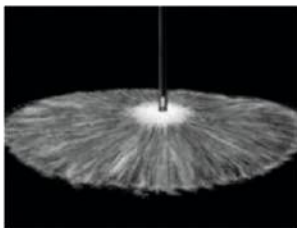
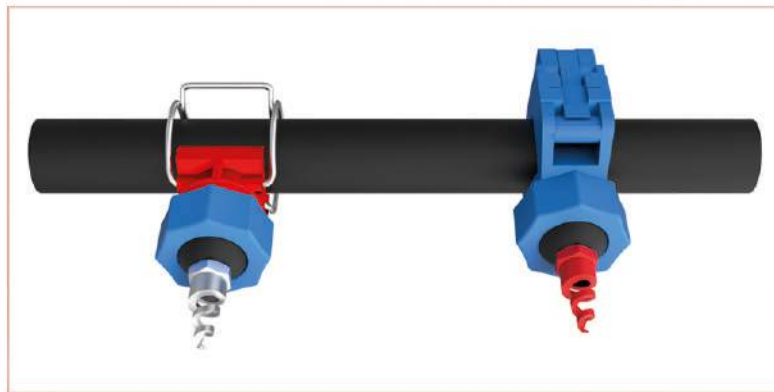
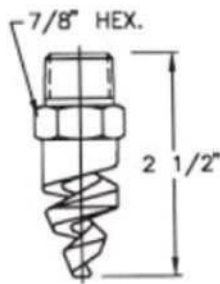

Full Cone 180°

### MS.TF29-180 Flow Rates and Dimensions

Extra-wide Spray Angle, 1/2" Pipe Size

Male Pipe Size	Nozzle Number	K Factor	GALLONS PER MINUTE @ PSI										Approx Free Pass. & Orifice Dia. (in.)	Wt. (lbs)
			10 PSI	20 PSI	30 PSI	40 PSI	50 PSI	60 PSI	80 PSI	100 PSI	200 PSI	400 PSI		
1/2	MS.TF29-180-16	1.21	3.81	5.38	6.59	7.61	8.51	9.32	10.8	12.1	17.1	24.1	0.204	0.15
	MS.TF29-180-18	1.91	6.01	8.50	10.5	12.1	13.5	14.8	17.1	19.1	26.9	38.0	0.251	0.15
	MS.TF29-180-21	2.30	7.26	10.4	12.7	14.6	16.3	17.9	20.6	23.0	32.5	46.0	0.282	0.23
	MS.TF29-180-24	3.01	9.51	13.5	16.6	19.1	21.3	23.4	27.0	30.1	42.6	60.2	0.329	0.19
	MS.TF29-180-28	3.92	12.5	17.6	21.5	24.8	27.7	30.4	35.0	39.2	55.3	78.2	0.376	0.17
	MS.TF29-180-32	5.51	17.5	24.7	30.2	34.9	39.0	42.7	49.3	55.1	77.9	111	0.439	0.15

# Spiral Nozzles MS.ST



## DESIGN FEATURES

- | Tank Washing Nozzle
- | Designed for more energy saving
- | Designed with Cobalt Alloy 6 or
- | RBC ceramic parts against wearing
- | Both male and female connections
- | Wide free passage design

## SPRAY CHARACTERISTICS

- | Full cone spraying
- | Spray angles of 90° & 120°
- | Flow rates from 2.12 to 3220 gmp

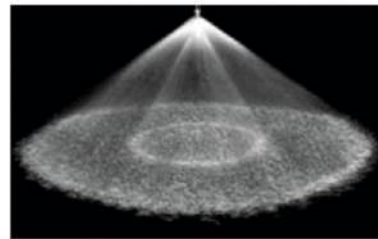
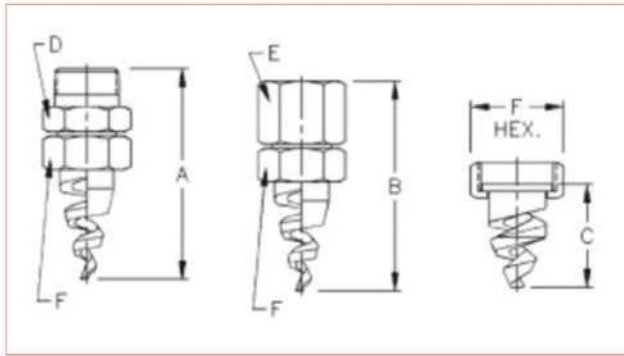

Full Cone 120°(XP)

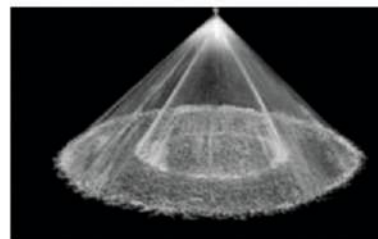

Full Cone 90°(XPN)

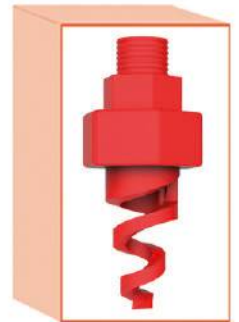

## MS.STXP Flow Rates & Dimensions

Flow Cone, 90° (XPN) and 120°(XP) Spray Angles, 3/8" to 4" Pipe Sizes

3-piece Male or Female Pipe Size	** 2-piece Female Pipe Sizes	Nozzle Number	K Factor	GALLONS PER MINUTE @ PSI												Approx (in.) Orifice & Free Pass. Dia.	Approximate Dimensions (in.)						Wt. (lbs.) Metal Male Fem.	
				5 PSI	10 PSI	15 PSI	20 PSI	30 PSI	40 PSI	50 PSI	60 PSI	80 PSI	100 PSI	200 PSI	400 PSI		A	B	C	D	E	F		
3/8		MS.ST12	0.950	2.13	3.01	3.68	4.25	5.21	6.01	6.72	7.36	8.50	9.50	13.5	19.1	0.20	3.95	3.40	2.14	1.39	1.39	1.51	0.6	0.6
		MS.ST14	1.21	2.87	4.06	4.97	5.74	7.02	8.11	9.07	9.93	11.6	12.9	18.2	25.7	0.23	3.95	3.40	2.12	1.39	1.39	1.51		
		MS.ST16	1.69	3.76	5.31	6.50	7.51	9.19	10.7	12.0	13.1	15.1	16.9	23.8	33.6	0.26	3.95	3.40	2.13	1.39	1.39	1.51		
		MS.ST20	2.62	5.84	8.26	10.2	11.8	14.4	16.6	18.5	20.3	23.4	26.2	37.0	52.3	0.32	3.95	3.40	2.13	1.39	1.39	1.51		
3/4		MS.ST24	3.82	8.53	12.2	14.9	17.1	21.0	24.2	27.0	30.0	34.2	38.2	54.0	76.3	0.39	4.57	3.82	2.69	1.20	1.20	1.75	1.2	1.2
		MS.ST28	5.23	11.8	16.6	20.3	23.4	28.7	33.1	37.0	40.5	46.8	52.3	73.9	105	0.45	4.57	3.82	2.69	1.20	1.20	1.75	1.2	1.2
		MS.ST32	6.64	14.9	21.1	25.8	29.8	36.5	42.1	47.1	51.5	59.5	66.5	94.0	134	0.51	5.15	5.13	4.23	1.51	1.51	2.20	2.1	2.1
1		MS.ST40	10.7	23.8	33.6	41.1	47.5	58.1	67.1	75.0	82.2	94.9	107	151	213	0.64	6.32	5.31	4.06	1.89	1.89	2.76	3.1	2.7
		MS.ST48	15.1	33.7	47.6	58.3	67.3	82.4	95.1	107	117	136	151	213	301	0.76	7.45	6.45	5.57	1.89	1.89	2.76		
1 1/2	1 1/2	MS.ST56	20.5	46.7	64.6	79.1	91.3	113	130	145	159	183	205	288	409	0.89	8.57	7.26	5.51	3.01	3.01	3.51	6.1	3.5
		MS.ST64	26.8	59.9	84.6	104	121	147	170	190	208	240	268	379	535	1.01	8.57	7.26	5.72	3.01	3.01	3.51		
		MS.ST72	30.5	68.0	96.1	119	137	167	193	216	236	273	305	430	608	1.14	8.89	7.64	5.74	3.01	3.01	3.51		
2	2	MS.ST88	44.4	99.1	141	172	199	243	281	314	344	397	444	627	886	1.39	11.9	8.01	6.39	3.64	3.64	4.01	8.1	4.1
		MS.ST96	56.0	126	178	217	251	307	355	396	434	501	561	792	1121	1.51	11.5	10.3	8.61	3.64	3.64	4.01		
3	3	MS.ST112	81.1	182	257	315	363	444	513	573	628	725	811	1151	1621	1.76	12.0	11.9	8.57	3.64	4.01	4.01	11	6.0
		MS.ST128	108	240	340	415	481	589	680	760	830	961	1071	1510	2151	2.01	12.7	11.9	8.57	3.64	4.01	4.01		
4	4	MS.ST160	167	372	526	644	743	910	1051	1171	1291	1481	1661	2351	3321	2.51	13.1	13.1	10.1	5.01	5.01	5.01	12	11

# Spiral Nozzles MS.TFXP



## DESIGN FEATURES

- More energy saving
- Male connection
- Extra wide free passage design
- Clog resistant

## SPRAY CHARACTERISTICS

- Full cone spraying
- Spray angles of 90° & 120°
- Flow rates from 3 to 3220 gpm

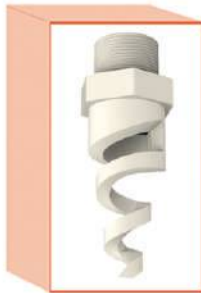

PTFE

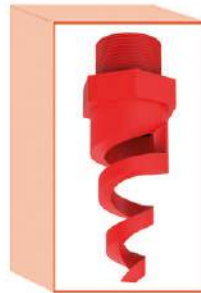

Plastic



Metal

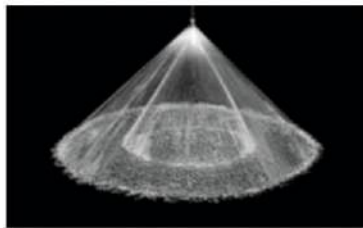
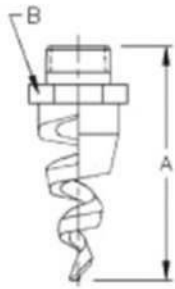

Full Cone 90° (XPN)

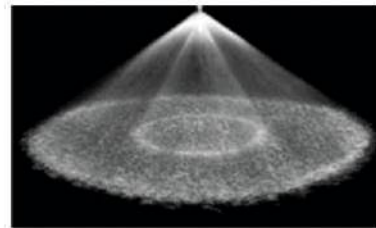

Full Cone 120° (XP)

### MS.TFXP Flow Rates and Dimensions

Full Cone, 90° (XPN) and 120° (XP) Spray Angles, 3/8" to 4" Pipe Sizes

Male Pipe Size	Nozzle Number	K Factor	GALLONS PER MINUTE @ PSI										Approx. Free Pass. & Orifice Dia. (in.)	Approximate Dimensions (in.) for Metal Only		Wt. (lbs.)	
			10 PSI	20 PSI	30 PSI	40 PSI	50 PSI	60 PSI	80 PSI	100 PSI	200 PSI	400 PSI		A	B	Metal	Plas.
3/8	MS.TF12	0.950	3.01	4.25	5.21	6.01	6.72	7.36	8.50	9.50	13.5	19.1	0.20	2.89	2.89	0.21	0.05
	MS.TF14	1.29	4.06	5.74	7.02	8.11	9.07	9.93	11.6	12.9	18.2	25.7	0.23	2.89	2.89		
	MS.TF18	1.69	5.31	7.51	9.3	10.7	12.0	13.1	15.1	16.9	23.8	33.6	0.26	2.76	2.76		
	MS.TF20	2.62	8.26	11.8	14.4	16.6	18.5	20.3	23.4	26.2	37.0	52.3	0.32	3.13	3.13		
1/2	MS.TF24	3.82	12.2	17.1	21.0	24.2	27.0	29.6	34.2	38.2	54.0	76.3	0.39	3.48	3.48	0.41	0.07
	MS.TF28	5.23	16.6	23.4	28.7	33.1	37.0	40.5	46.8	52.3	73.9	105	0.45	3.51	3.51		
3/4	MS.TF32	6.65	21.1	29.8	36.5	42.1	47.1	51.5	59.5	66.5	94.0	134	0.51	5.39	5.39	1.57	0.23
1	MS.TF40	10.7	33.6	47.5	58.1	67.1	75.0	82.2	34.9	107	151	213	0.64	5.26	5.26	1.57	0.26
	MS.TF48	15.1	47.6	67.3	82.4	95.1	107	117	135	151	213	301	0.76	6.64	6.64	2.07	0.48
1 1/2	MS.TF56	20.5	64.6	91.2	113	130	145	159	183	205	269	409	0.89	6.98	6.98	4.01	0.60
	MS.TF64	26.8	84.6	121	147	169	190	208	240	268	379	535	1.01	6.95	6.95	2.45	0.54
	MS.TF72	30.5	96.1	137	167	193	216	236	273	305	430	608	1.14	7.42	7.42	2.82	0.54
2	MS.TF88	44.4	141	199	243	281	314	344	397	444	527	886	1.39	10.6	10.6	5.13	1.26
	MS.TF96	56.0	178	251	307	355	396	434	501	560	792	1121	1.51	11.1	11.1	6.32	1.26
3	MS.TF112	81.1	257	363	444	513	573	628	725	811	1152	1621	1.76**	12.0	12.0	8.38	1.38
	MS.TF128	108	340	481	589	680	760	830	961	1071	1511	2151	2.04**	11.8	11.8	9.76	1.51
4	MS.TF160	167	526	743	910	1051	1171	1291	1481	1661	2351	3321	2.50**	12.1	12.1	15.7	1.88

# Spiral Nozzles MS.TF



### Common Applications

Exhaust gas filtration  
Gas cooling  
Clog resistant  
More Energy saving  
Male connection

Washing and rinsing  
Fireproofing and fire extinguishment  
Designed without any internal parts  
Designed to provide more fluid discharge velocity

### Spray Angle Visual:



Full Cone 60° (NN)



Full Cone 90° (FCN)

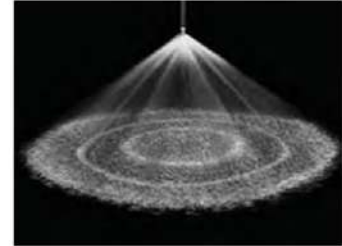

Full Cone 150°/ 170°



pipe connection BSPT (out)	Spray angle (0.7 bar)					Capacity Size	orifice size (mm)	Diameter of nozzle without black (mm)	Capacity (L/min)				
	60°	90°	120°	150°	170°				0.7 bar	1.5 bar	3 bar	7 bar	25 bar **
1/4		○	○			13	3.2	3.2	4.9	7.3	10.3	15.7	30
3/8	○	○	○	○	○	30	4.8	3.2	11.4	16.7	24	36	68
1/2		○	○			82	7.9	3.2	31	46	65	99	187
				○		120	9.5	4.8	45	67	95	145	270
3/4		○	○			164	11.1	4.8	62	92	129	198	370
1		○	○			210	12.7	4.8	80	117	166	255	480
1-1/2		○	○			340	15.9	6.4	130	190	270	410	775
			○			640	22.2	7.9	245	355	505	770	1460

**Model MED.201.00  
Tank Mixing Eductors**



**for improved in-tank solution  
circulation and agitation**



Inlet Conn. NPT or BSPT(M)	Approx Flow Rate Performance	Inlet Liquid Pressure								
		10 psi	15 psi	20 psi	25 psi	30 psi	35 psi	40 psi	50 psi	70 psi
1/4	Inlet Flow Rate (gpm) "A"	3.5	4.3	5.0	5.5	6.1	6.6	7.0	7.8	7.8
3/8		9	11	12.5	14	16	17	18	20	24
3/4		13.5	17	19	21	23	25	27	30	36
1-1/2		33	40	47	53	58	63	66	75	89
1/4	Entrained Liquid (gpm) "B"	15.1	15.1	17.8	19.6	22	24	26	29	29
3/8		36	44	50	56	64	68	72	80	96
3/4		54	68	76	84	92	100	108	120	141
1-1/2		132	160	188	212	232	252	264	300	366
1/4	Circulation Rate (gpm) "A" + "B"	16.2	19.4	22.8	25.1	28.1	30.6	33	36.8	36.8
3/8		45	55	62.5	70	80	85	90	100	120
3/4		67.5	85	95	105	115	125	135	150	177
1-1/2		165	200	235	265	290	315	330	375	455
1/4	Effective Flow Field (feet)	3	5	7	8.5	10	12	14	17	17
3/8		4	6	8	10	12	14	16	22	28
3/4		5	8	11	14	17	20	24	33	50
1-1/2		7.5	1.2	16	20	24	29	34	46	57

Inlet Conn. NPT or BSPT(M)	Approx Flow Rate Performance	Inlet Liquid Pressure								
		.5 bar	1 bar	1.5 bar	2 bar	2.5 bar	3 bar	3.5 bar	4 bar	5 bar
1/4	Inlet Flow Rate (l/min) "A"	11.3	16.0	19.5	23	25	28	30	32	7.8
3/8		29	42	51	59	65	70	77	82	91
3/4		43	64	74	85	97	106	116	124	136
1-1/2		106	151	184	215	243	259	288	308	337
1/4	Entrained Liquid (l/min) "B"	42	59	72	84	93	102	110	118	29
3/8		116	168	204	236	260	280	308	328	363
3/4		172	256	296	340	388	424	464	496	534
1-1/2		424	604	736	860	972	1036	1152	1232	1348
1/4	Circulation Rate (l/min) "A" + "B"	53.3	75	91.5	107	118	130	140	150	36.8
3/8		145	210	255	295	325	350	385	410	454
3/4		215	320	370	425	485	530	580	620	670
1-1/2		530	755	920	1075	1215	1295	1440	1540	1685
1/4	Effective Flow Field (meters)	.91	1.5	2.1	2.6	3.00	3.7	4.3	5.2	17
3/8		1.2	1.8	2.4	3	3.7	4.3	4.9	6.7	9.1
3/4		1.5	2.4	3.4	4.3	5.2	6.1	7.3	10.1	15.6
1-1/2		2.3	3.7	4.9	6.1	7.3	8.8	10.4	14.0	17.8



## Engineering Considerations

### Tank Turnover

The capacity and number of tank mixing eductors is determined by the turnover rate.

The turnover rate is defined as the number of times the entire liquid contents of tank is completely circulated through the eductors per hour. Please note that the turnover rate will vary according the characteristics of the application. For example:

Most plating and rinsing tanks require 3 to 20 turnovers per hour.

Other plating tanks may require more than 30 turnovers per hour.

Cleaning tanks require at least 10 turnovers per hour. Heavily soiled tanks require up to 20 turnovers per hour.

Critical cleaning tanks require turnover rates of more than 20 turnovers per hour. To find the required flow per minute, multiply the appropriate turnover rate by the tank volume, then divide by 60. By using the performance chart, find the eductor that has best eddective flow field for your tank configuration.

Once the eductor size has been found, the number of eductors can be determined by dividing the circulaation rate of this eductor at the given pressure into the required flow per minute.

### Tank Mixing Eductor Configurations

In larger tanks, eductors positioned around the tank provide more affective mixing than one centrally located eductor. Also, little agitation occurs below the level of the eductor. Eductors should be positioned as close as possible to the bottom of the tank for maximum liquid turnover. Here are a few examples of typical eductor configurations.

### Nozzle Application:



## Compact desing simplifies mounting; saving time and money

The Model MED.201.00 Tank Mixing Eductor also features a very compact desing, its compact size prevents the eductor from interfering with plating racks and other in tank equipment. Plus, its in-tank mountaing capability eliminates the need for intracate above tank mounting structures.



## To learn more about the Model MED.201.00 Tank Mixing Eductor...

Additional enformation is available on the Model MED.201.00 Tank Mixing Eductor. Contact your local Systems CO. sales engineer to learn more or visit our web site at: [www.mitsuda.com.tr](http://www.mitsuda.com.tr)



## Expanded line includes more material choices and inlet connection sizes

The Model MED.201.00 Tank Mixing Eductor is constructed for excellent durability, corrosion resistance, and chemical resistance. For general use applications, like cleaning, coating, mixing, and rinsing, the eductor is available in glass-reinforced polypropylene or cast 316 stainless steel. The polypropylene version features a 1/4

" 3/8", 3/4" or 1-1/2" NPT or BSPT (M) inlet connection and has a \*maximum operating temperature of 200 F (93 C) at 50 psi (3.5 bar). Inlet connection sizes for the stainless steel model include 3/8", and, 1-1/2" NPT or BSPT (M).

New to the line is a KYNAR® (PVDF) version of the Model MED.201.00 Tank Mixing Eductor. The KYNAR eductor was designed expressly for improved solution circulation and agitation in plating applications for circuit board manufacturing . In this application, the eductors aid in the process of cothode film removal. With the eductors mounted on a series of headers at the side of the plating tank, circulation between the plating racks and across the circuit board surface increases-allowing for improved plating. It is available with a 1/4" NPT or BSPT (M) inlet connection and has a " maximum operating temperature of 220° F (104°C) at 50 psi (3.5 bar).

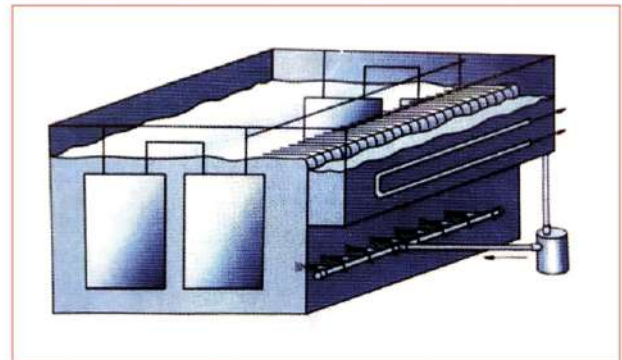

Eductors used in paint electro-deposition line manufacturing.

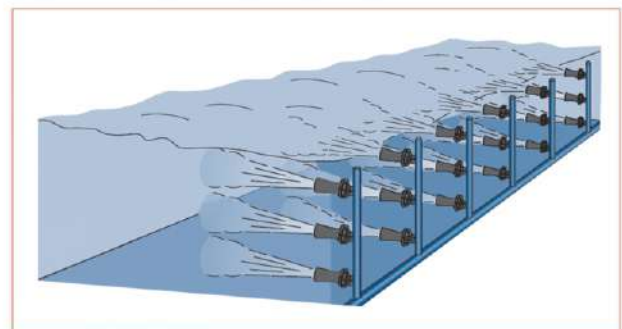

## Typical Applications

- | Anodizing
- | Cleaning
- | Electrocoating
- | Mixing
- | Painting Booths
- | Phosphating
- | Plating
- | Rinsing
- | Sludge removal
- | Stripping

\*Maximum temperature is based on water Maximum operating temperature may be affected by tank chemicals or processes. Consult your local MITSUDA Systems Co. sales engineer for additional information.

## Tank Mixing Eductors...a cost-effective method for optimizing liquid tank performance

## Eductor's large flow opening and "flow through"

## Chamber minimize clogging for maximum liquid circulation



Several distinct operating principles are key to the Model MED.201.00 Tank Mixing Eductor's in-tank performance. First of all, liquid under pressure is pumped into the eductor through its large flow opening that helps minimize clogging. As the liquid exits the eductor at high velocity, it draws surrounding solution through eductor's "flow-through" chamber that's designed to eliminate internal material build up. Then, this additional liquid flow mixes with the pumped solution and multiplies its volume. This means that the eductor can pull in or "entrain" up to 4 additional gallons (15.1 liters) of surrounding solution for every 1 gallon (3.8 liters) pumped through the eductor.

**MITSUDA** Systems Co.'s Model MED.201.00 Tank Mixing Eductor, when combined with a centrifugal pump, improves liquid circulation and agitation in closed or open recirculating process tanks. The eductor contains no moving parts to wear out or maintain. It provides a homogeneous fluid mix between the bottom and top of the tank without the use of costly and inefficient air agitation. Not only is it a cost-effective way for achieving optimum liquid tank performance, it also allows smaller pumps to circulate larger volumes of tank solution for possible energy savings.

Because of this multiplying effect, smaller pumps can be used to circulate large volumes of liquid. Since smaller pumps are less expensive to purchase and they use less energy to operate, significant cost savings can be realized.

### Additional eductor benefit: reduced maintenance, improved products quality

The eductor prevents particulate from setting on the tank bottom. By keeping the particulate in suspension, filtration system clogging is prevented. This translates to a cleaner tank and reduced maintenance time. Products quality is also maintained or improved since the eductor's high circulation.

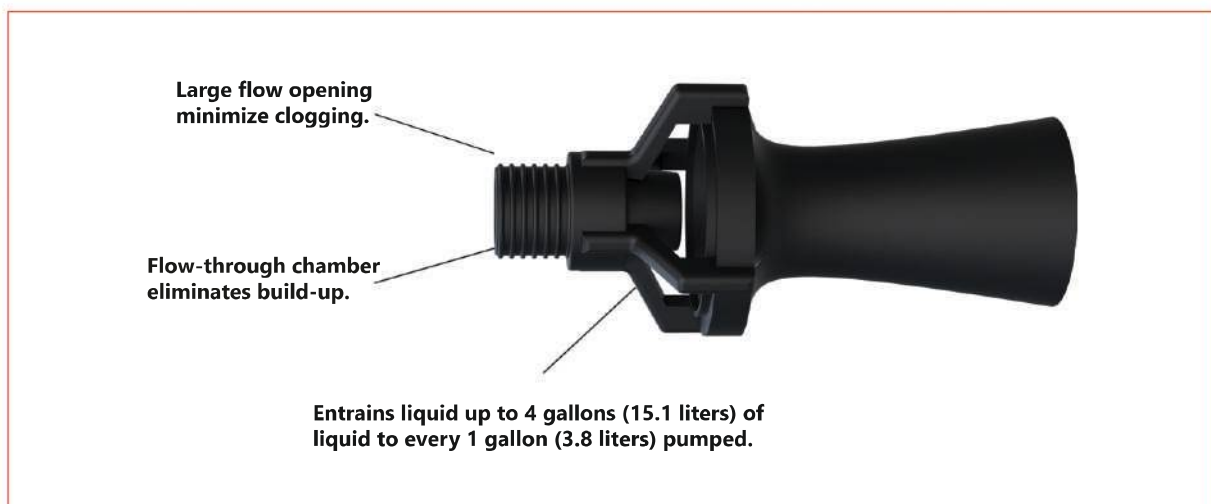

## Model MED.201.00 Tank Mixing Eductor Specifications Dimensions & Weights

	Model No.	Inlet Conn. NPT or BSPT(M)	Orifice Dia.	Length	Dia.	Net Weight		
						K Y	P	SS
	MED.201.00.01.PP	1/4	3/16" (5mm)	3" (76mm)	1-1/4" (32mm)	.51 oz (.01kg)	.51 oz (.01kg)	—
	MED.201.00.03.PP	3/8	5/16" (5mm)	4-1/16" (103mm)	1-11/16" (52mm)	—	1 oz (.03kg)	9.9 oz (.28kg)
	MED.201.00.05.PP	3/4	3/8" (5mm)	6-3/8" (162mm)	3" (76mm)	—	2.8 oz (.08kg)	24.5 oz (.69kg)
	MED.201.00.09.PP	1-1/2	9/16" (5mm)	10" (254mm)	4-1/2" (114mm)	—	10.2 oz (.29kg)	73.5 oz (2.1kg)

### Material

Material	Material Code	Eductor Model No. MED.201.00-			
		1/4	3/8	3/4	1.1/2
KYNAR	KY	•			
Polypropylene	PP	•	•	•	•
Cast 316 Stainless Steel	SS		•	•	•

### Ordering Info

TANK MIXING EDUCTOR (WITH NPT CONNECTION)		
MED.201.00	- 3 / 8	PP
Model No.	Inlet Conn.	Material Code

TANK MIXING EDUCTOR (WITH BSPT CONNECTION)		
MED.201.00	- 3 / 8	SS
Model No.	Inlet Conn.	Material Code



### Accessories



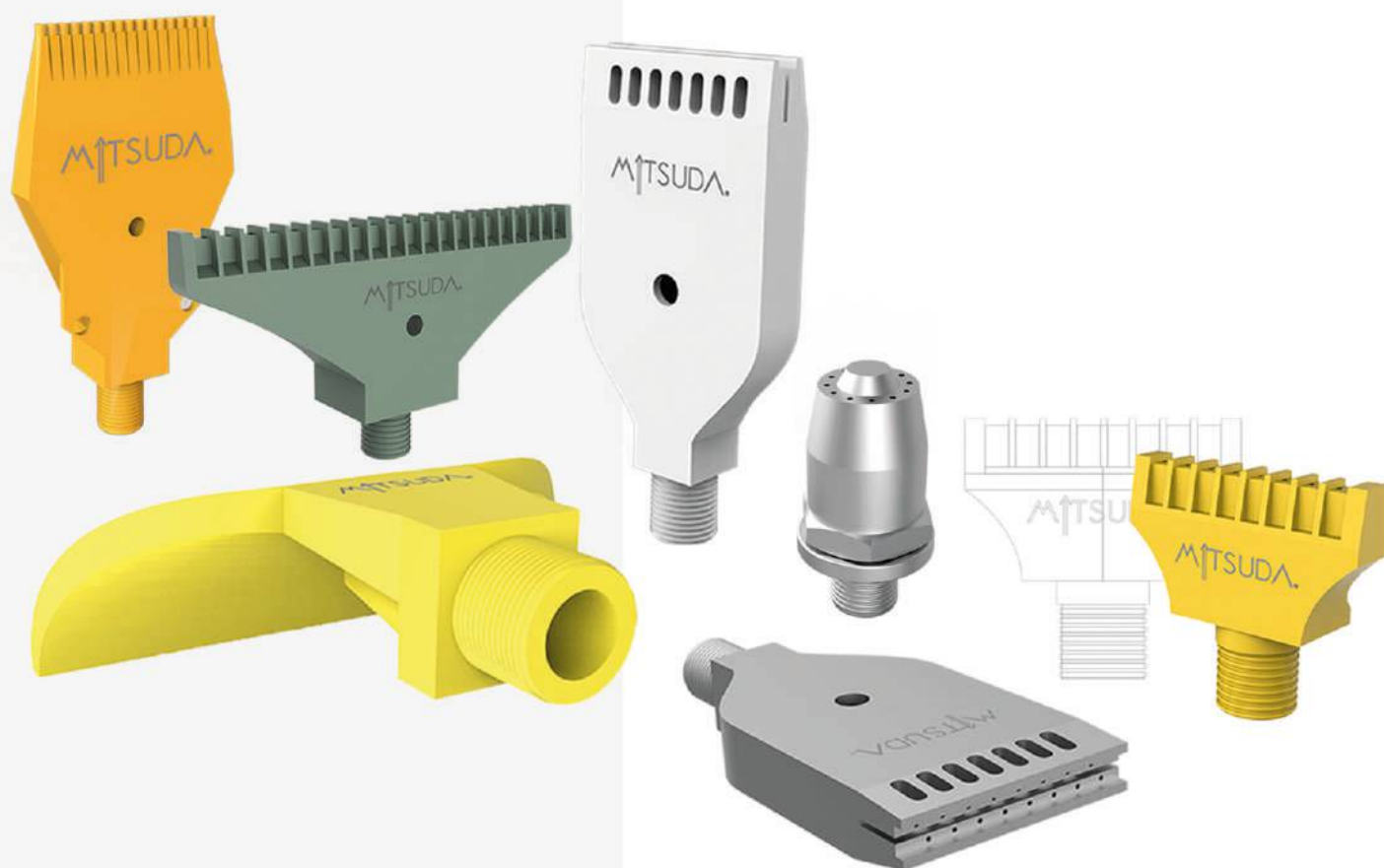

**MHT.600.332**

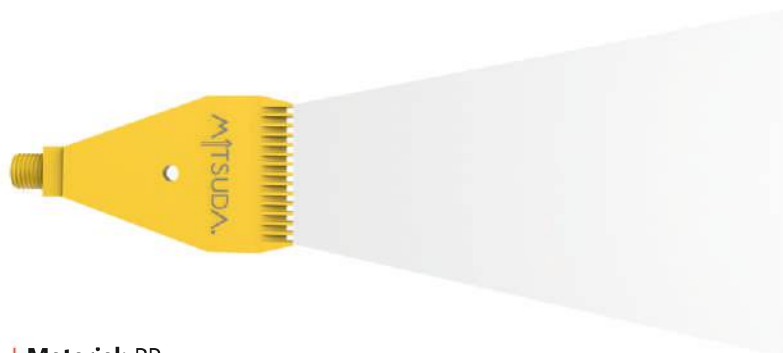

- | **Material:** PP
- | **Blowing force :** 2 N at 2 bar
- | **Noise Level:** 70 db(A) at 2 bar
- | **Air consumption:** VLN = 15 m<sup>3</sup>/h at 2 bar
- | **Pressure:** Pmax = 6 bar
- | **Max. temperature:** 55°C

**MHT.600.300**



- | **Material:** PP
- | **Blowing force :** 2 N at 2 bar
- | **Noise Level:** 78 db(A) at 2 bar
- | **Air consumption:** VLN = 22 m<sup>3</sup>/h at 2 bar
- | **Pressure:** Pmax = 10 bar
- | **Max. temperature:** 55°C

**MHT.600.130**



- | **Material:** Stainless Steel 316L SS
- | **Blowing force :** 2 N at 2 bar
- | **Noise Level:** 76 db(A) at 2 bar
- | **Air consumption:** VLN = 15 m<sup>3</sup>/h at 2 bar
- | **Pressure:** Pmax = 25 bar
- | **Max. temperature:** 550 C



## MHT.600.493

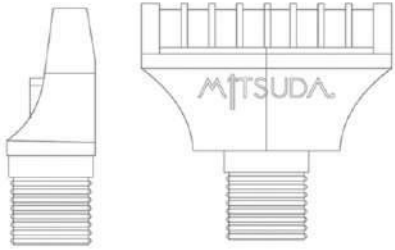

- | **Material:** PP
- | **Blowing force :** 2 N at 2 bar
- | **Noise Level:** 74 db(A) at 2 bar
- | **Air consumption:**  $V_{LN} = 13\text{m}^3/\text{h}$  at 2 bar
- | **Pressure:**  $P_{max} = 7.5$  bar
- | **Max. temperature:** PP nature : 55°C

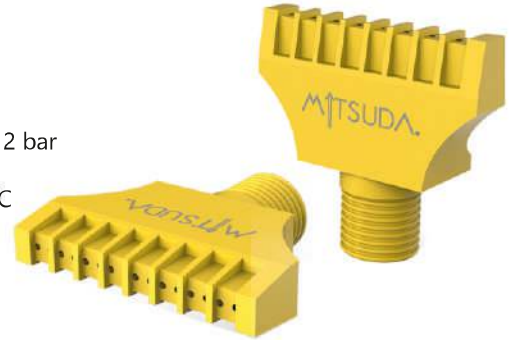

## MHT.600.606



- | **Material:** Aluminum
- | **Blowing force :** 1.4 N bei at 2 bar
- | **Noise Level:** 68.5 db(A) at 2 bar
- | **Air consumption:**  $V_{LN} = 12 \text{ m}^3/\text{h}$  at 2 bar
- | **Pressure:**  $P_{max} = 11$  bar
- | **Max. temperature:** 200°C

## MHT.600.326.5K



- | **Material:** PP
- | **Blowing force :** 2 N.N at 2 bar
- | **Noise Level:** 74 db(A) at 2 bar
- | **Air consumption:**  $V_{LN} = 15 \text{ m}^3/\text{h}$  at 2 bar
- | **Pressure:**  $P_{max} = 6$  bar
- | **Max. temperature:** PP nature : 55°C

## MHT.600.326.3W



- | **Material:** Stainless Steel 316L SS
- | **Blowing force :** 2 N.1 at 2 bar
- | **Noise Level:** 79 db(A) at 2 bar
- | **Air consumption:**  $V_{LN} = 15 \text{ m}^3/\text{h}$  at 2 bar
- | **Pressure:**  $P_{max} = 6$  bar
- | **Max. temperature:** PP nature<sup>®</sup>: 50 C



The multi-channel flat fan jet nozzles of the MHT.600.332 series generate a continuous powerful air jet. The noise level and air consumption remain Low even at higher air pressures. The projecting tips at the nozzle outlet prevent air penetration into human skin. These nozzles comply with the OSHA standards.

**26 % Cost Saving**

**21 % Noise reduction**

Material	Blowing force	Noise level	Air consumption	Pressure	Max. temperature
PP	2 N at 2 bar	70 dp(A) at 2 bar	VLN = 15 m <sup>3</sup> /h at 2 bar	Pmax = 6 bar	55 °C

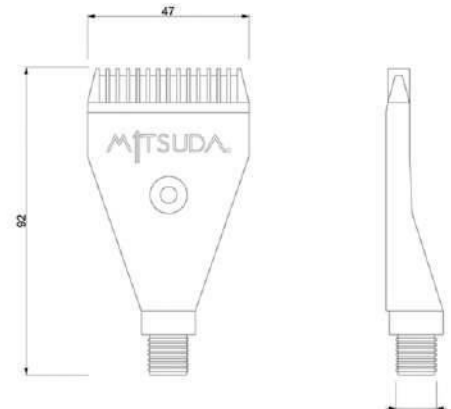
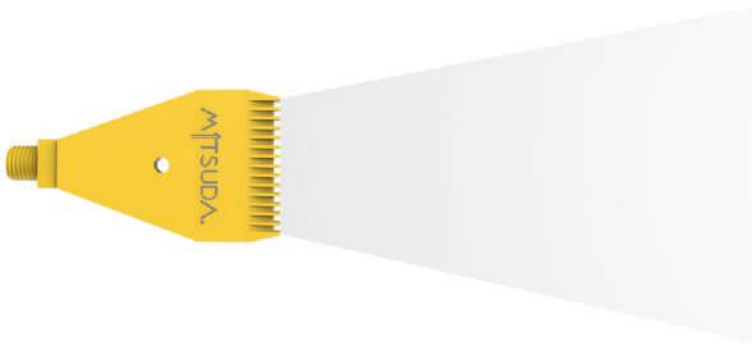

Pressure	1 bar	3 bar	5 bar
Distance L [mm]	625	900	900
A [mm]:	125	200	230
B [mm]:	125	200	230

Ordering no.			
Type	Mat no.	Code	
	POM	1/4 BSPP	1/4 NPT
MHT.600.332	<input type="radio"/>	AC	BC

Example for ordering: Type MHT.600.332 + Mat no. 56 + Code AC = Ordering no. MHT.600.332.56.AC





The multi-channel round jet nozzles of the MHT.600.326 series generate a powerful, circular air jet. The noise level and air consumption remain low even at higher air pressures. The special geometry at the nozzle outlet prevents air penetration into human skin. These nozzles comply with the OSHA standards.

**9% Cost Saving**

**17% Noise reduction**

Material	Blowing force	Noise level	Air consumption	Pressure	Max. temperature
PP	2 N.N at 2 bar	74 db(A) at 2 bar	$V_{LN} = 15 \text{ m}^3 / \text{h}$ at 2 bar	$P_{max} = 6 \text{ bar}$	PP nature : 55°C



Pressure	1 bar	3 bar	5 bar
Distance L [mm]	700	900	900
A [mm]:	160	220	260
B [mm]:	160	220	260

Ordering no		Connection Thread
Type	Code	
<b>MHT.600.326.5K</b> (Material: ABS)	<b>AC</b>	1/4 BSPP
	<b>AA</b>	1/8 BSPP
	<b>BA</b>	1/8 NPT
	<b>BC</b>	1/4 NPT
	<b>HG</b>	M12 x 1.25

Example for ordering: Type MHT.600.326.5K + Code AC = Ordering no. MHT.600.326.5K

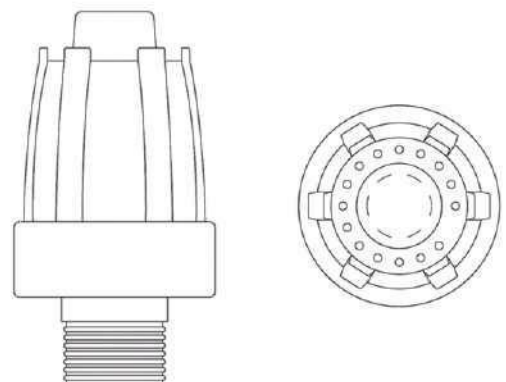

Nominal Diameter	Major Diameter	Tapping Drill Size	TPI	Pitch
	mm	mm		mm
1/16"	7.722	6.60	28	0.907
1/8"	9.728	8.80	28	0.907
1/4"	13.157	11.80	19	1.337
3/8"	16.662	15.25	19	1.337
1/2"	20.955	19.00	14	1.814
5/8"	22.911	21.00	14	1.814
3/4"	26.441	24.50	11	1.814
1"	33.249	30.75	11	2.309
1-1/4"	41.910	39.5	11	2.309
1-1/2"	47.803	45.25	11	2.309
2"	59.614	57.00	11	2.309
2-1/2"	75.184	72.60	11	2.309
3"	87.884	85.30	11	2.309
4"	113.030	110.40	11	2.309
5"	138.430	135.473	11	2.309
6"	163.830	160.873	11	2.309

PPRC Pipe Diameter	DN	Inch
Ø20	DN15	1/2"
Ø25	DN20	3/4"
Ø32	DN25	1"
Ø40	DN32	1-1/4"
Ø50	DN40	1-1/2"
Ø63	DN50	2"
Ø75	DN65	2-1/2"
Ø90	DN80	3"
Ø110	-	-
Ø125	DN100	4"





**MITSUDA**  
Spray Nozzle

[www.spreynozul.com](http://www.spreynozul.com)



Agency

Head Office: Mimar Sinan Mah. Yedpa Ticaret Merkezi F Cad. No: 143. Ataşehir / İstanbul - T: +90 216 471 09 87 PBX  
F: +90 216 471 09 94 - [www.spreynozul.com](http://www.spreynozul.com) - [www.mitsuda.com.tr](http://www.mitsuda.com.tr) - [www.spraynozzles.net](http://www.spraynozzles.net)  
[info@mitsuda.com.tr](mailto:info@mitsuda.com.tr)

Copyright© 2023 All Rights Reserved.